



# ATLANTA

**Operating and Maintenance Instructions**

**BWL 350**

**4100-001-12.93**

Dept.		<b>TS - Screw Jack Gearbox Translation from German original</b>	Page	1	56
Rev.Index			Name	Gansemer	2014-04-14
Date			Released		

Index: Subject	Page
General safety notes, general notes, exclusion of liability	2-3
1. Short description, marking	4-5
2. Proper use, improper use	5-6
3. Transport and weights	7-8
4. Preparing the installation	8-10
4.1. Checklist for mounting and start-up	9
4.2. True-running check at the spindle of gear units with rotating spindle	10
5. Installation	11–24
5.1. Mounting the limit-switch set for gear units with non-rotating spindle	11-12
5.2. Mounting the fork link / spherical plain bearing rod head / swivel head for gear units with non-rotating spindle	13
5.3. Mounting the spindle nut for gear units with rotating spindle	14
5.4. Mounting the safety grip nut for gear units with rotating spindle	15
5.5. Mounting the nut swivel bearing for gear units with rotating spindle	16
5.6. Mounting the mating bearing flange for gear units with rotating spindle	16
5.7. Mounting the bellows	17
5.8. Mounting the pivot block / lugs	18
5.9. Mounting the swivel bolts	19
5.10. Mounting the driving flange	20-21
5.11. Mounting the drive coupling	22
5.12. Mounting the motor	23
5.13. Mounting the hand-wheel	24
6. Electrical start-up	24–25
7. Mechanical start-up	26–43
7.1. Lubricating instructions for screw-jack gearboxes	27
7.2. Test run of screw-jack gearbox before the installation	28-30
7.3. Installation of the screw-jack gearbox in the system	31-32
7.4. Installation of screw-jack gearbox with non-rotating spindle in the system	32-33
7.5. Installation of screw-jack gearbox with rotating spindle in the system	34-36
7.6. Installation of set of screw-jack gearboxes	37-38
7.6.1. Mounting the universal shaft with key connection	39-42
7.6.2. Mounting the pillow blocks	43
8. Operation	44
9. Maintenance, maintenance intervals	45–52
9.1. Cleaning the spindle from old grease	46
9.2. Cleaning the basic gear unit	46
9.3. Changing the gearbox lubricant	47
9.4. Measuring the wear of the trapezoidal thread nut	47-49
9.5. Replacing the trapezoidal thread nut	49
9.6. Measuring the wear of the motor brake	50
9.7. Replacing the spindle	51
10. Storage	53
11. Disposal	53
12.1. Motor connection diagram for three-phase motors without brake and limit switches at the protective tube for gear units with non-rotating spindle	54
12.2 Motor connection diagram for three-phase motors with brake	55



# ATLANTA

Operating and Maintenance Instructions

## BWL 350

### 4100-001-12.93

Dept.		<b>TS - Screw Jack Gearbox</b> <b>Translation from German original</b>	Page	2	56
Rev.Index			Name	Gansemer	2014-04-14
Date			Released		

**ATLANTA does not assume liability for any damage to the transmission or any resulting consequential damage, if these instructions are not observed.**

#### Explanation of symbols:



Danger of personal injury



Risk of damage to gearbox or machine/system



Important information



Directions and instructions for the operation in areas with explosion hazard

#### General safety notes:



Improper working may lead to injuries and damage:



- Flung about foreign matter can cause injuries. Do not leave any foreign matter or tools near the lifting unit when taking it into operation or operating.
- Touching hot surfaces may cause burns. Wear protective gloves.
- Keep distance from rotating or straight traversing machine components. There is the risk that hair or parts of the body or hair are squeezed or pulled in.
- Should you notice any damage or defect of the TS screw-jack gearbox, you must not take it into operation. Inform ATLANTA.



# ATLANTA

## BWL 350

### Operating and Maintenance Instructions

### 4100-001-12.93

Dept.	
Rev.Index	
Date	

**TS - Screw Jack Gearbox**  
**Translation from German original**

Page	3	56
Name	Gansemer	2014-04-14
Released		

#### General instructions:



**Operation in areas with explosion hazards are only allowed, if a specific name plate for  - operation is on the gearbox. See chapter 1.1.**

The instructions identified by  are to be observed. They are prepared on the basis of the ignition danger rating KGA 130.

#### ATTENTION!



The observance of the operating and maintenance instructions is prerequisite for trouble-free operation of the system and the acceptance of possible warranty claims.

Therefore read these instructions before starting work with the screw-jack gearbox! Pay special attention to the safety instructions!

These operating and maintenance instructions are part of your product and contain important information regarding maintenance and service; therefore they should always be kept close to the screw-jack gearbox.

In addition, comply with any national or regional regulations regarding safety and prevention of accidents!



Residual risks to persons or property may arise from the TS-screw-jack gearboxes. For this reason, any assembly, installation, start-up, and/or service work may be performed only by skilled or specially trained personnel being aware of possible risks.

The personnel must be qualified for the work to be done and familiar with the assembly, installation, starting-up procedure and the operation of the product. Furthermore the complete operating and maintenance instructions must be carefully read, understood, and respected. Only qualified personnel may perform the following work:

Transport and handling, storage, erection, installation, electric connection, start-up, maintenance, repair.



Within the meaning of the EC Machinery Directive 2006/42/EG the TS screw-jack gearbox is no machine but a component to be incorporated into machines. Within the scope of the EC Machinery Directive its operation is prohibited until it is ensured that the machine into which this screw-jack gearbox is to be installed is in compliance with the directions of the EC Machinery Directive.



Changes and modification of the TS screw-jack gearbox may be made only with express written permission of ATLANTA Antriebssysteme E.Seidenspinner GmbH & Co. KG.

ATLANTA Antriebssysteme E.Seidenspinner GmbH & Co. KG reserves the right to make technical changes to improve the product. .

#### Disclaimer:



The manufacturer shall not be liable for damage or injury arising from improper handling of the TS screw-jack gearbox.

Unprofessional handling or any other acts that are not in accordance with these instructions impair the properties of the product. This leads to the waiver of any kind of warranty claims against the Company ATLANTA Antriebssysteme E.Seidenspinner GmbH & Co. KG.



# ATLANTA

## Operating and Maintenance Instructions

### BWL 350

### 4100-001-12.93

Dept.		<b>TS - Screw Jack Gearbox</b> <b>Translation from German original</b>	Page	4	56
Rev.Index			Name	Gansemer	2014-04-14
Date			Released		

### 1. Short description

The ATLANTA TS-standard screw-jack gearboxes (series 61 3x xxx und 61 4x xxx) are used for the conversion of rotary motions into linear motions. They are mainly driven by three-phase motors. Manual operation is also possible. After consultation with ATLANTA other motors may be permissible as special version, e.g. servomotors.

The gear units are available with non-rotating spindle or rotating spindle. As standard version they are equipped with trapezoidal-thread spindle and nut. The light-metal housing ensures optimal heat dissipation.

The gear units are delivered with grease filling, test-run, tested for tightness, and are consequently ready for operation.

The initial grease filling of the spindles is sufficient for approx. 10 strokes.

#### 1.1. Marking

The TS screw-jack gearbox is provided with a nameplate containing the following information:

The types TS 2, TS 5, TS 10 and TS 25 are provided with the following nameplate:

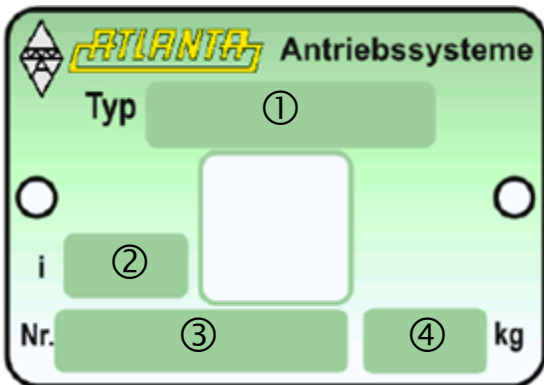

- ① Part number of the basic gear unit.
- ② Reduction
- ③ Serial number
- ④ Weight [kg]

The types TS 50 and TS 100 bear the following nameplate:

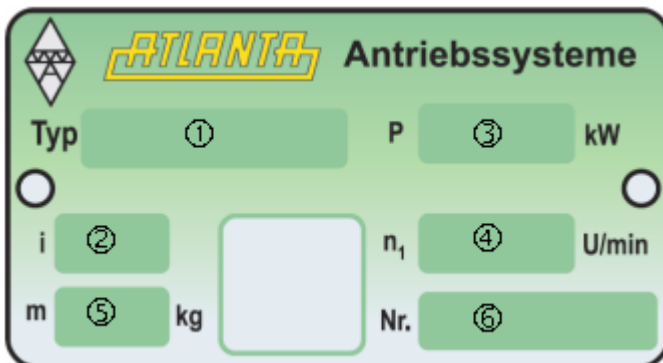

- ① Part number of the basic gear unit
- ② Reduction
- ③ Max. capacity [kW] with S3 operation (at stated max. speed)
- ④ Max. speed [ $\text{min}^{-1}$ ] with S3 operation
- ⑤ Weight [kg]
- ⑥ Serial number



# ATLANTA

## BWL 350

### Operating and Maintenance Instructions

### 4100-001-12.93

Dept.	
Rev.Index	
Date	

**TS - Screw Jack Gearbox**  
**Translation from German original**

Page	5	56
Name	Gansemer	2014-04-14
Released		



When used in potentially explosive areas the gear unit must show the corresponding marking on an extra label. Only then it may be used in this specific area. Special attention should be paid to the category listed there.

Example of an ATEX nameplate:

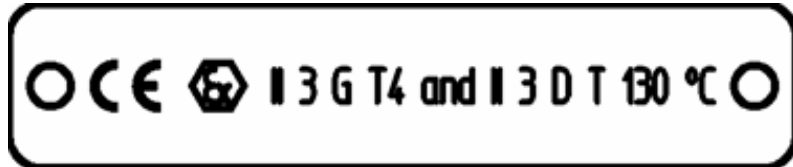

## 2. Proper use :



When operated in areas with explosion hazard the instructions identified by the symbol are to be observed.

The ATLANTA screw-jack gearboxes may only be used for the conversion of rotary motions into linear motions in mechanical engineering applications under atmospheric pressure conditions.



The permissible input speed and output torque must not be exceeded. The layout instructions according to the ATLANTA catalogue have to be observed.

The gear unit may be operated only in rooms with normal ambient pressure. The gear unit must not be operated outdoors or at increased ambient pressure, and also not under water or other liquids.

The gear unit may be operated only at ambient temperatures between -10 °C and +40 °C.

Other temperatures and working conditions are possible with special designs and are subject to the approval by ATLANTA:

The gear unit is designed for intermittent operation (S3 acc. to DIN EN 60034-1). The duty cycles mentioned in the catalogue must not be exceeded.

Continuous operation (S1 acc. to DIN EN 60034-1) is not permissible without written approval by ATLANTA.

The gear unit must not be used in combination with combustion engines – danger of overheating, inadmissible shock loading!

The gear unit is designed for power input via the worm shaft. The efficiency rating stated refers to power input via the worm-shaft.



In combination with trapezoidal-thread spindles the gearbox unit is statically self-locking, but not self-braking. The self-locking feature can be reduced or neutralized by vibrations, unfavourable lubrication conditions and smoothing of the surface after running in.



The lifting unit may not be driven on mechanical stops. The Lmin and Lmax measures on the nameplate must be observed. If the gear unit is run to the stops, components will be overloaded causing damage.

Deviation from this requirement is only permitted if a low speed is chosen and the motor is switched off before reaching 150% of the torque required for moving the load.



# ATLANTA

## BWL 350

### Operating and Maintenance Instructions

### 4100-001-12.93

Dept.

Rev.Index

Date

**TS - Screw Jack Gearbox**  
**Translation from German original**

Page

6

56

Name

Gansemer

2014-04-14

Released



The surface temperature of the gearbox must not exceed 80°C during operation.



When used in areas with explosion hazard, it may be necessary to measure the surface temperature and to ensure warning or cut-off, if the temperature of 65°C is exceeded.



Differing working conditions require written approval by ATLANTA.

### 2.1. Improper use:



Any use where the permissible limit values of lifting capacity and input speed, the operating conditions and temperature ranges stated, and the other conditions mentioned under 2 are exceeded, shall be considered improper use and shall consequently be forbidden.

This applies equally, if the gear unit and its attachments

- are not assembled properly
- are not installed properly
- are installed with tensions
- are very dirty
- are not sufficiently lubricated
- if dirt, foreign matter (e.g. chippings), or other pollutions are in the grease on the spindle from where they might get into the nut



# ATLANTA

## BWL 350

### Operating and Maintenance Instructions

### 4100-001-12.93

Dept.	
Rev.Index	
Date	

**TS - Screw Jack Gearbox**  
**Translation from German original**

Page	7	56
Name	Gansemer	2014-04-14
Released		

### 3. Transport



Transport and handling may be carried out only by qualified or specially trained personnel. Observe the safety regulations applying to transport and handling with lifting tackle. The load should be handled and set down slowly and cautiously.



No special bores or threads are provided for transporting the gear unit. There are, however, many threaded fastening holes in the gearbox where eye-bolts can be screwed in, thus enabling safe transportation and handling.



It must be assured that no loads (particularly no bending stresses) act upon the spindle and the gear unit.



In gear units with non-rotating spindle the protective tube must not be subject to any bending stresses.



Improper transportation of the gear unit can cause damage to the output-shaft bearing or the spindle drive resulting in a considerably reduced service life of the gear unit and the spindle.

Weights in kilograms:

Gear unit	Basic gear	Spindle per meter	Driving flange with coupling	Max. size three-phase motor	Pivot lugs		Swivel bolts (pair)
					long	short	
TS 2	0.65	0.9	0.5	5.2	0.2		0.1
TS 5	1.1	1.6	0.6	7.8	0.4		0.2
TS 10	2.0	2.0	0.9	11.7	0.4	0.5	0.2
TS 25	3.6	4.5	1.2	23.5	0.9	0.7	0.5
TS 50	10	8.2	2.1	37	4.5	3.6	0.9
TS 100	17	19	2.9	70	6.7	5.4	2.2

Gear unit	Protective tube per meter	Twisting protection	Limit switch set	Fixing flange	Fork link	Rod head	Swivel head
TS 2	2.1	0.12	0.7	0.2	0.1	0.1	-
TS 5	2.1	0.12	0.7	0.25	0.2	0.2	0.3
TS 10	2.7	0.20	0.8	0.4	0.2	0.2	0.5
TS 25	5.4	0.40	0.9	0.6	0.6	0.5	1.2
TS 50	7.3	1.3	1.1	1.25	2.0	1.2	2.4
TS 100	10.8	1.4	1.2	3.4	5.4	2.9	8.5



# ATLANTA

## Operating and Maintenance Instructions

### BWL 350

### 4100-001-12.93

Dept.		<b>TS - Screw Jack Gearbox</b> <b>Translation from German original</b>	Page	8	56
Rev.Index			Name	Gansemer	2014-04-14
Date			Released		

Gear unit	Flanged running nut	High-performance running nut	Duplex nut	Swivelling running nut	Grip nut	Nut swivel bearing
TS 2	0.25	0.5	0.25	---	0.1	---
TS 5	0.25	0.55	0.25	0.7	0.1	1.0
TS 10	0.35	0.75	0.35	1.5	0.1	0.9
TS 25	0.5	1.6	0.5	2.4	0.2	1.4
TS 50	1.7	3.1	1.7	5.1	0.4	2.3
TS 100	3.9	6.7	3.9	22	1.2	6.8

#### 4. Preparing the installation



Installation work may be carried out only by qualified or specially trained personnel.



Inspect the gear unit for outside damage and soiling. A damaged or soiled gear unit must not be installed or operated.



Cleaning with high-pressure cleaners is not permissible. It leads to the destruction of the seals and penetration of water into the gearbox and consequently to premature failure of the gear unit.



Do not clean the gear unit, and in particular the area of the seals, with sharp-edged objects and liquid cleaning agents.





# ATLANTA

Operating and Maintenance Instructions

## BWL 350

### 4100-001-12.93

Dept.		<b>TS - Screw Jack Gearbox</b> <b>Translation from German original</b>	Page	9	56
Rev.Index			Name	Gansemer	2014-04-14
Date			Released		

#### 4.1. Check list for mounting and start-up

##### Before beginning the installation and start-up

What has to be checked?	Checked
<b>Delivery:</b> <ul style="list-style-type: none"> <li>Does the scope of delivery comply with the shipping documents?</li> <li>Report any shipping damage immediately to the forwarder.</li> <li>Report any visible damage/incompleteness immediately to ATLANTA Antriebssysteme E. Seidenspinner GmbH &amp; Co. KG.</li> </ul>	
<span style="border: 1px solid black; padding: 2px;">Ex</span> <b>Application in areas with explosion hazard:</b> <ul style="list-style-type: none"> <li>Do the following specifications on the nameplate of the gearbox comply with the permissible ex-range conditions on site?               <ul style="list-style-type: none"> <li>Explosion group</li> <li>Category</li> <li>Temperature class</li> <li>Max. surface temperature</li> </ul> </li> <li>Are all components or attachments to be mounted suitable for use within the respective ex-protected application?</li> </ul>	
<b>Ambient temperature:</b> <ul style="list-style-type: none"> <li>Will the ambient temperature range between -10°C and + 40°C be kept?               <ul style="list-style-type: none"> <li>The maximum ambient temperature of 40°C must not be exceeded at any time during the operation.</li> <li>The temperature must not fall below the minimum of -10°C at any time during the operation.</li> </ul> </li> </ul>	
<b>Ventilation:</b> <ul style="list-style-type: none"> <li>Is sufficient ventilation of the gear units provided to ensure adequate heat dissipation?</li> </ul>	
<b>Nameplate specifications:</b> <ul style="list-style-type: none"> <li>Are the specifications stated on the nameplate of the gear unit not exceeded?</li> </ul>	

##### During start-up

What has to be checked?	Checked
<b>Environment:</b> <ul style="list-style-type: none"> <li>It must be ensured that no explosive atmospheres, oils, acids, gases, vapors, or combustible dusts are present!</li> <li>Exception: The gear unit is allowed for such environment and provided with a corresponding additional ATEX plate.</li> </ul>	
<b>Temperature measurement:</b> A temperature measurement is <b>obligatory</b> after 3 hours of operation under maximum load permissible for the respective application! <ul style="list-style-type: none"> <li>The temperature measurements must be made in the area of the drive in places that are protected from the flow of cooling air. It is advisable to measure at different points to determine the maximum temperature.</li> <li>An absolute temperature of 80°C on the surface of the housing or nut must not be exceeded.</li> <li>When used in areas with explosion hazard the surface temperature must not exceed 65°C.</li> </ul>	



# ATLANTA

## Operating and Maintenance Instructions

# BWL 350

## 4100-001-12.93

Dept.	
Rev.Index	
Date	

**TS - Screw Jack Gearbox**  
**Translation from German original**

Page	10	56
Name	Gansemer	2014-04-14
Released		

### 4.2. True-running check at the spindle of gear units with rotating spindle:



**In order to make sure that there is no transport damage check the spindle for true-running before installing the gear unit in the system!**

Position and clamp the gear unit horizontally. Place the dial indicator on a level support on the workbench and put the measuring sensor on the nut. With motor disconnected, turn the input shaft by hand until at least one full revolution of the spindle is completed.

Measuring position 1:

Permissible radial divergence (=value indicated by dial indicator): 0.1 mm

Measuring position 2:

Permissible radial divergence (=value indicated by dial indicator) depending upon the length of the spindle measured from the front edge of the gear unit:

Spindle length	Radial divergence for gear units TS2, TS5, TS10 und TS25	Radial divergence for gear units TS50 und TS100
Up to 500 mm	1.0 mm	0.5 mm
501-1000 mm	2.0 mm	1.0 mm
1001-1500 mm	3.0 mm	1.5 mm
1501-2000 mm	4.0 mm	2.0 mm

**Please contact us, if the permissible radial divergence is exceeded.**

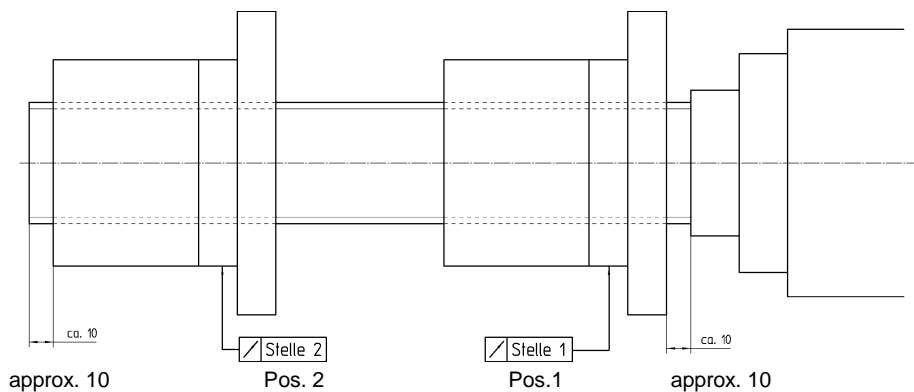



# ATLANTA

Operating and Maintenance Instructions

## BWL 350

### 4100-001-12.93

Dept.	
Rev.Index	
Date	

**TS - Screw Jack Gearbox**  
**Translation from German original**

Page	11	56
Name	Gansemer	2014-04-14
Released		

## 5. Installation



Mounting work may be carried out only by qualified or specially trained personnel.



**Warning!**

Rotating or straight moving parts may catch pieces of clothing, hair and members of the body and injure persons. It must be ensured that persons cannot be endangered by any rotating or straight moving components during the installation.



Screw-jack gearboxes or any individual components must always be mounted free from tensions.

### 5.1. Mounting the limit-switch set for gear units with non-rotating spindle:



The mechanical limit switches can be used both as operation limit switches and as safety limit switches. They are provided with forced mechanical disconnection. Due to this they can be used as safety limit switches in accordance with the accident prevention rules of the German professional association.

The inductive limit switches can be used as operation limit switches. Whether their use as safety limit switches is permissible, has to be determined by the user.



The gearbox is supplied with the necessary bores inside the protective tube. The limit switches are usually enclosed separately.

If the bores are executed on the site, mind the following points:

- The protective tube must **always** be removed for this work. Otherwise chippings may fall onto the spindle, stick in the grease and thus be carried into the spindle.
- Position the bores so that they are covered when the plate with screwed-in limit switch is fitted.
- Do not use long slotted holes because they would reduce the strength of the protective tube.
- After drilling, clean the tube from chips. Trim the bores inside and outside the tube.
- The protective tube has a welded seam inside which must be fitted into the recess of the twisting protection.
- Always use screws of the same length for re-mounting the protective tube.

Screw the limit switches into the plate to the dimension required. For this purpose proceed as shown in the following table and in the drawings 1 and 2. Tighten the nut on the limit switch.

Clamp the plate with the bracket on the protective tube. Make sure that the limit switch is positioned in the middle of the bore. Tighten the screws only slightly.

Now start the gear unit as described under para. 7.



# ATLANTA

## Operating and Maintenance Instructions

### BWL 350

### 4100-001-12.93

Dept.	
Rev.Index	
Date	

### TS - Screw Jack Gearbox Translation from German original

Page	12	56
Name	Gansemer	2014-04-14
Released		

Gear unit	Installation dimension "x" [mm] with mechanical limit-switch set acc. to drawing 1	Installation dimension "x" [mm] with inductive limit-switch set acc. to drawing 2
61 32 8xx	17,3 -0,5	9,3 -0,5
61 33 8xx	17,3 -0,5	9,3 -0,5
61 34 8xx	17,3 -0,5	9,3 -0,5
61 35 8xx	18,4 -0,5	10,4 -0,5
61 36 8xx	18,5 -0,5	10,5 -0,5
61 37 8xx	19,6 -0,5	11,6 -0,5

drawing 1                      drawing 2  
Einbaumaß = Installation dimension

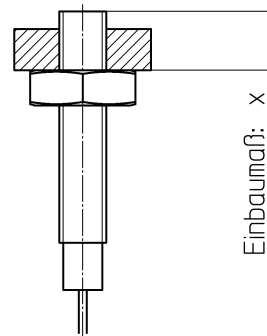
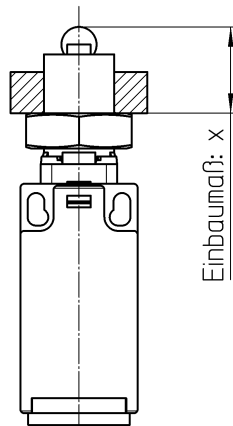

After installing the gear unit in the system, check if the limit switches function as desired. You can adjust the switching point by displacing the limit switch axially along the axis of the protective tube.

Do not reduce or increase the screwing depth. The mechanical limit switch is provided with forced mechanical disconnection. The installation dimension is chosen to suit this switching point. If it is not possible to reach the switching point by axial displacement, please contact us.

When using a mechanical limit switch, make sure that the maximum switching path is not exceeded.

When using an inductive limit switch, take care that it does not extend into the inside of the protective tube.

After determining the required switching positions tighten the screws at the bracket with an indicating torque wrench to 5.9 Nm and lock the nut of the limit switch.



When used in areas with explosion hazard, only limit switches meeting the ATEX requirements are permitted. The limit switches of the standard program range are not suitable for such applications.



When used in areas with explosion hazard, suitable corrosion protection (e.g. greasing, painting, zinc coating) must be provided, if there is a risk that mechanical sparking may occur. Also corrosion protected screws have to be used.



# ATLANTA

## BWL 350

### Operating and Maintenance Instructions

### 4100-001-12.93

Dept.	
Rev.Index	
Date	

**TS - Screw Jack Gearbox**  
**Translation from German original**

Page	13	56
Name	Gansemer	2014-04-14
Released		

## 5.2. Mounting the fork link / spherical plain bearing rod head / swivel head for gear units with non-rotating spindle:

The fork link / spherical plain bearing head / swivel head is usually supplied non-assembled.



Screw the fork link / spherical plain bearing head / swivel head onto the spindle end and adjust according to the mounting position. When mounted, there must not be any tensions between fork link / spherical plain bearing head / swivel head and twisting protection.



The fork link / spherical plain bearing head / swivel head must be connected with the spindle in such a way that the spindle torque can be reliably transmitted. The chosen type of connection must be verified by means of calculation.



The fork link / spherical plain bearing head / swivel head must be carefully adjusted according to the attachment in the system.

When using the locknuts supplied with the unit, position them to the measurement X as shown below and then screw on the attachment. Adjust by turning the locknut as required towards the trapezoidal thread (max. half a turn).

Then tighten the nut against the attachment to the torque specified. Additionally secure both nut and attachment against loosening (e.g. with Loctite 243).

If an extra pin is available, screw it also in and secure it.

In systems comprising several screw-jack gearboxes also consider para. 7.6.



When used in areas with explosion hazard, suitable corrosion protection (e.g. greasing, painting, zinc coating) must be provided, if there is a risk that mechanical sparking may occur.

Gear unit	Size of nut	Strength
TS 2	M 8	04
TS 5	M 12	04
TS 10	M 14	04
TS 25	M 20	04
TS 50	M 30	04
TS 100	M 42x2	04

Gear unit	Tightening torque <sup>1)</sup>	Dimension X
TS 2	9 Nm	12
TS 5	28 Nm	18.5
TS 10	44 Nm	20
TS 25	130 Nm	21.5
TS 50	450 Nm	29
TS 100	1200 Nm	48

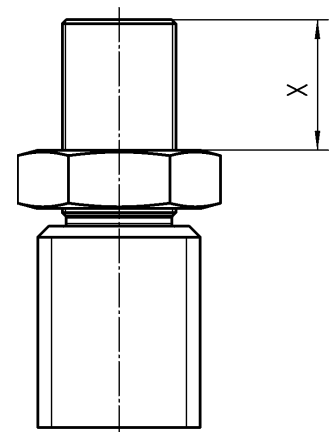

<sup>1)</sup> Only use calibrated torque wrenches! If the tightening torque is too low, the required torque will not be transmitted. If the tightening torque is too high, the nuts will be overstrained and become unusable.



# ATLANTA

Operating and Maintenance Instructions

**BWL 350**

**4100-001-12.93**

Dept.	
Rev.Index	
Date	

**TS - Screw Jack Gearbox**  
**Translation from German original**

Page	14	56
Name	Gansemer	2014-04-14
Released		

### 5.3. Mounting the spindle nut for gear units with rotating spindle:



Spindle and nut must be perfectly aligned. Lateral forces and bending forces are not permissible. They lead to increased wear and tear.



The alignment between spindle and nut must be carefully checked in order to exclude the danger of overheating the spindle drive. This check must be repeated after 10 hours of operation und working conditions.



The nut must be mounted under the point of load as shown in the following sketches. See also para. 7.5.

**Hochleistungs-Laufmutter**  
 Heavy-duty running nut

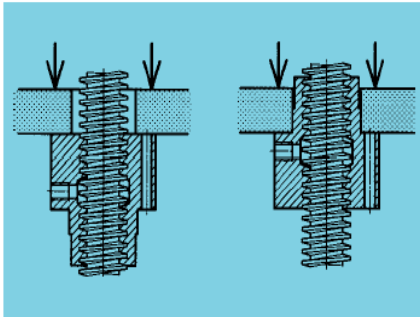

**Flansch-Laufmutter**  
 Flanged running nut

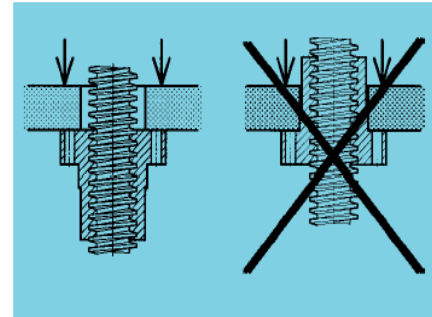

Tightening torque of screws according to table below. If possible, choose the direction of the load/power input so that the load is conducted via the supporting surface and not via the screws. Use washers because of the permissible surface pressure of the bronze.

Gear unit	Strength class of screws	Screws flange nut	Tightening <sup>*)</sup> torque	Screws high-perform. running nut	Tightening <sup>*)</sup> torque
TS 2	8.8	M 5	5.9 Nm	M 5	5.9 Nm
TS 5	8.8	M 5	5.9 Nm	M 5	5.9 Nm
TS 10	8.8	M 6	10 Nm	M 6	10 Nm
TS 25	8.8	M 6	10 Nm	M 8	25 Nm
TS 50	8.8	M 8	25 Nm	M 10	48 Nm
TS 100	8.8	M 12	84 Nm	M 12	84 Nm

<sup>\*)</sup> Only use calibrated torque wrenches! If the tightening torque is too low, the required torque will not be transmitted. If the tightening torque is too high, the nuts will be overstrained and become unusable. Secure screws against loosening (e.g. with Loctite 243).



# ATLANTA

## BWL 350

### Operating and Maintenance Instructions

### 4100-001-12.93

Dept.	
Rev.Index	
Date	

### TS - Screw Jack Gearbox Translation from German original

Page	15	56
Name	Gansemer	2014-04-14
Released		



Self-aligning running nuts can make up for a misalignment angle of max. 3° between axle of spindle and screwing surface of nut. This can help to reduce the wear of the nut, if the screwing surface of the nut is designed as welded construction.



Self-aligning running nuts can neither make up for alignment errors between spindles nor angle errors between fixing surfaces of the gearboxes and guides.

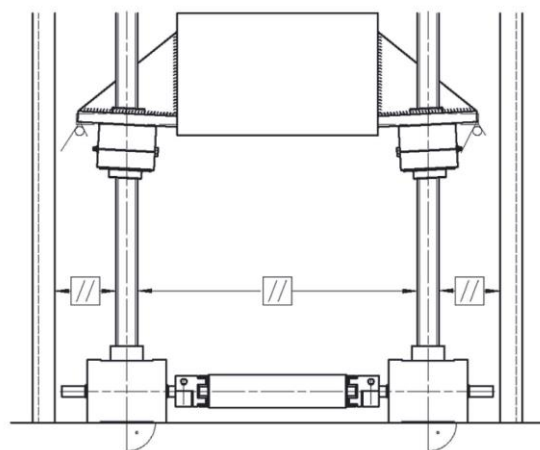
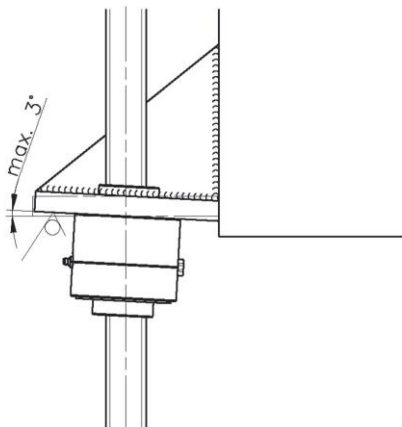

#### 5.4. Mounting the safety grip nut for gear units with rotating spindle:



Safety grip nuts for gear units with non-rotating spindle are special designs. In this case, please request special documentations. In the case of gear units with rotating spindle the units are supplied with safety grip nut mounted.



**The safety grip nut must always be arranged behind the nut when looking in the direction of the load. It is effective only in this direction.**



For the installation of the screw-jack gearbox in the system it is usually necessary to remove the running nut. When remounting it, make sure to adjust the distance between running nut and safety grip nut again correctly. The dimension „X“ adjusted, when the unit is supplied, is noted on the nameplate attached to the gear unit. It should be posted visibly near the grip nut. Thus it is possible to determine the wear by means of the difference in distance. See para. 9.4.



# ATLANTA

## Operating and Maintenance Instructions

### BWL 350

### 4100-001-12.93

Dept.	
Rev.Index	
Date	

**TS - Screw Jack Gearbox**  
**Translation from German original**

Page	16	56
Name	Gansemer	2014-04-14
Released		

### 5.5. Mounting the flange-nut swivel bearing in gear units with rotating spindles:



The flange-nut swivel bearing is usually loosely enclosed with the gear unit supplied. It must then be screwed to the flange nut in the position as required. For the proper tightening torque see the table below.

The flow of forces should, if possible, be chosen in such a way that the force passes over the supporting surface and not over the screws.



Choose the length of the screws so that optimal use is made of the available depth of thread. When used in areas with explosion hazard, suitable corrosion protection (e.g. greasing, painting, zinc coating) must be provided, if there is a risk that mechanical sparking may occur.

Also corrosion protected screws have to be used.

Gear unit	Thread	Depth of thread
TS 5	M 5	10 mm
TS 10	M 6	12 mm
TS 25	M 6	12 mm
TS 50	M 8	14 mm
TS 100	M12	20 mm

### 5.6. Mounting the mating bearing flange for gear units with rotating spindle:



The mating bearing flange is usually loosely enclosed. Hold the mating bearing flange against the spindle end. Install the inner bearing ring with a mounting sleeve by slightly tapping with a plastic hammer.

Rotate the bearing and check for easy running.

Screw it to the system. See para.7.5. Tighten the screws as stated in the table below.

Sufficient screwing depth at the attachment according to VDI 2230 must be ensured.



When used in areas with explosion hazard, suitable corrosion protection (e.g. greasing, painting, zinc coating) must be provided, if there is a risk that mechanical sparking may occur.

Also corrosion protected screws have to be used.

Screw size	Strength class of the screws	Tightening <sup>*)</sup> torque
M 8	8.8	25 Nm
M 10	8.8	48 Nm
M 12	8.8	84 Nm
M 20	8.8	415 Nm

<sup>\*)</sup> Use only calibrated torque wrenches! If the tightening torque is too low, the required torque will not be transmitted. If the tightening torque is too high, the screws will be overstrained and become useless. Secure screws against loosening (e.g. with Loctite 243).





# ATLANTA

## BWL 350

### Operating and Maintenance Instructions

### 4100-001-12.93

Dept.		<b>TS - Screw Jack Gearbox</b> <b>Translation from German original</b>	Page	17	56
Rev.Index			Name	Gansemer	2014-04-14
Date			Released		

#### 5.7. Mounting the bellows:



When used in areas with explosion hazard, it must be ensured that the bellows cannot come in touch with any attachments and will not brush against anything during operation, in order to avoid electrostatic charging.

It may be advisable to measure the electrostatic charge.

Special designs for areas with explosion hazards are also available.



**Bellows reduce the heat radiation of the spindle to approx. 50 %. Therefore the gear unit may only be operated for half the nominal operating time under operating load conditions. Please contact us, if you are in doubt.**



#### **Gear unit with non-rotating spindle:**

In the case of gear units with non-rotating spindle the bellows is mounted between nut protection and optional spindle mounting flange, spherical plain bearing rod head, swivel head or a customer-specific attachment.

It is usually supplied assembled and mounted to the gear unit.

Slide both cuffs of the bellows over the respective attachments. Fasten with hose clamps.

Make sure that the bellows is not twisted.



#### **Gear unit with rotating spindle:**

In the case of gear units with rotating spindle one bellows is usually attached to the gear unit and the other one is enclosed loosely because the nut must be removed for the installation of the gear unit in the system. The bellows can be fixed only after the gear unit is installed in the system. See also Chapter 7.5.

When attaching the bellows, always make sure that it is not twisted.

The bellows must be safely fixed so that the cuffs or ends of the bellows cannot slip off from the attachments.

The space the bellows takes up in compressed condition, must be considered in the design. The bellows must neither be compressed too much nor overstretched.

Depending upon the mounting situation, supporting rings are provided in the bellows in order to prevent the bellows from coming into contact with the spindle. They must not be removed!



The bellows must always be adequately ventilated. For this purpose our bellows are provided with vent openings. Make sure that they remain unobstructed so that the air can flow in and out freely.



# ATLANTA

## Operating and Maintenance Instructions

### BWL 350

### 4100-001-12.93

Dept.	
Rev.Index	
Date	

### TS - Screw Jack Gearbox Translation from German original

Page	18	56
Name	Gansemer	2014-04-14
Released		

### 5.8. Mounting the pivot block or lugs:



In the case of types TS2 and TS5 the pivot block is usually one piece. In the case of bigger gearboxes there are lugs provided for the different swivelling directions.

The pivot block / lugs are usually enclosed loosely together with the screws.

Screw the pivot block /lugs and the gear unit together. Tightening torque acc. to table below. The flow of forces should, if possible, be chosen in such a way that the force passes over the supporting surface and not over the screws.

Choose the screw lengths so that the full depth of the thread is made use of.



When used in areas with explosion hazard, suitable corrosion protection (e.g. greasing, painting, zinc coating) must be provided, if there is a risk that mechanical sparking may occur. Also corrosion protected screws have to be used.

Gear unit	Size of screws	Strength class of the screws	Tightening <sup>1)</sup> torque
TS 2	M6 x 35	8.8	8 Nm
TS 5	M8 x 40	8.8	17 Nm
TS 10	M8 x 45	8.8	17 Nm
TS 25	M10 x 55	8.8	33 Nm
TS 50	M12 x 75	8.8	70 Nm
TS 100	M16 x 100	8.8	180 Nm

<sup>1)</sup> Use only calibrated torque wrenches! If the tightening torque is too low, the required torque will not be transmitted. If the tightening torque is too high, the screws will be overstrained and become useless. Secure screws against loosening (e.g. with Loctite 243).



# ATLANTA

## BWL 350

### Operating and Maintenance Instructions

### 4100-001-12.93

Dept.	
Rev.Index	
Date	

**TS - Screw Jack Gearbox**  
**Translation from German original**

Page	19	56
Name	Gansemer	2014-04-14
Released		

#### 5.9. Mounting the swivel bolts:



The interface between swivel pins and the adjacent construction must be rigid. Deflections cause additional stresses on the screws (both the swivel bolts and the pivot block / lugs) whereby they may be overloaded and may break.



The force may only be applied in the direction of the screws. Lateral forces on the screws are not permitted.



The flow of forces should, if possible, be chosen in such a way that the force passes over the supporting surface and not over the screws. Should this be impossible, the load may not exceed half the rated load in the case of gear units TS10 to TS100.

The two bolts must be mounted coaxially. The mounting surfaces of the adjacent construction must be even, parallel and on the same level.

The bolts must be mounted in such a way that there is only slight axial play to the bearing bushes of the pivot block / lugs.

Sufficient screwing depth must be ensured on the adjacent construction in accordance with VDI 2230.



When used in areas with explosion hazard, suitable corrosion protection (e.g. greasing, painting, zinc coating) must be provided, if there is a risk that mechanical sparking may occur. Also corrosion protected screws have to be used.

Screw size	Strength class of the screws	Tightening <sup>*)</sup> torque
M 5	10.9	8,6 Nm
M 6	10.9	15 Nm
M 8	10.9	36 Nm
M 10	10.9	71 Nm
M 12	10.9	123 Nm

<sup>\*)</sup> Use only calibrated torque wrenches! If the tightening torque is too low, the required torque will not be transmitted. If the tightening torque is too high, the screws will be overstrained and become useless. Secure screws against loosening (e.g. with Loctite 243).



# ATLANTA

## BWL 350

### Operating and Maintenance Instructions

### 4100-001-12.93

Dept.		<b>TS - Screw Jack Gearbox</b> <b>Translation from German original</b>	Page	20	56
Rev.Index			Name	Gansemer	2014-04-14
Date			Released		

#### 5.10. Mounting the driving flange:

The driving flange and the bolts/washers are usually loosely enclosed.



We recommend to proceed as follows:

- Before attaching the driving flange clean all contact surfaces.
- Insert the driving flange into the gear centring piece and tighten the screws at first only slightly.
- In the case of gear units TS25, 50 und 100 first screw the adapter ring to the gear unit and then the driving flange to the adapter ring.

Tighten screws alternately crosswise. Tightening torque according to table.

Choose the length of the screws so as to make maximal use of the available depth of thread.

Insert washers under all screws on the driving flange for improved contact pressure on the aluminum surface.



When used in areas with explosion hazard, the opening in the driving flange (for tightening the fixing screw for the coupling) should be mounted so that it looks to the side or downward. Improper installation can lead to unacceptably high temperatures.



When used in areas with explosion hazard, suitable corrosion protection (e.g. greasing, painting, zinc coating) must be provided, if there is a risk that mechanical sparking may occur. Also corrosion protected screws have to be used.

Mounting sizes TS 2 to TS 10.

In the case of these sizes the motor flange is screwed directly to the gear unit.

Gear unit	Screw size	Washer	Depth of thread [mm] inside housing	Strength class of screws	Tightening <sup>*)</sup> torque
TS 2	M5	no	6	8.8	5.6 Nm
TS 5	M6	no	9	8.8	9 Nm
TS 10	M8	no	10	8.8	21 Nm

<sup>\*)</sup> Use only calibrated torque wrenches! If the tightening torque is too low, the required torque will not be transmitted. If the tightening torque is too high, the screws will be overstrained and become useless. Secure screws against loosening (e.g. with Loctite 243).



# ATLANTA

## Operating and Maintenance Instructions

# BWL 350

## 4100-001-12.93

Dept.  
Rev.Index  
Date

### TS - Screw Jack Gearbox Translation from German original

Page 21 56  
Name Gansemer 2014-04-14  
Released

Mounting sizes TS 25 to TS 100.

In the case of these sizes, first screw the adapter ring to the gear unit and then the motor flange to the adapter ring.

Screwing the adapter ring to the gear unit:

Gear unit	Screw size	Washer	Depth of thread [mm] in housing	Strength class of screws	Tightening <sup>1)</sup> torque
TS 25	M8	no	12	8.8	25 Nm
TS 50	M10	no	16	8.8	48 Nm
TS 100	M12	no	22	8.8	70 Nm

Screwing the motor flange to the adapter ring:

Gear unit	Screw size	Washer	Depth of thread [mm] in adapter ring	Strength class of screws	Tightening <sup>1)</sup> torque
TS 25	M6	yes	12	8.8	10 Nm
TS 50	M10	yes	25	8.8	48 Nm
TS 100	M10	yes	20	8.8	48 Nm

<sup>1)</sup> Use only calibrated torque wrenches! If the tightening torque is too low, the required torque will not be transmitted. If the tightening torque is too high, the screws will be overstrained and become useless. Secure screws against loosening (e.g. with Loctite 243).

In the case of the TS25 the 3 screws must be arranged in the direction of the gravitational force of the motor.

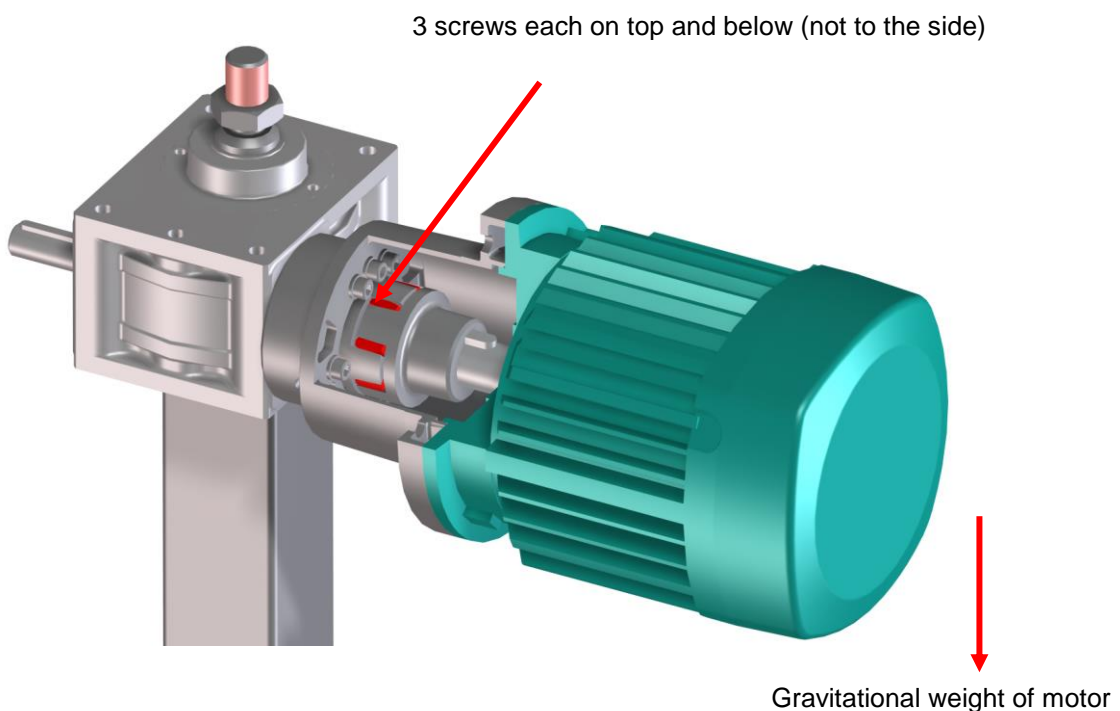



# ATLANTA

## Operating and Maintenance Instructions

### BWL 350

### 4100-001-12.93

Dept.	
Rev.Index	
Date	

**TS - Screw Jack Gearbox**  
**Translation from German original**

Page	22	56
Name	Gansemer	2014-04-14
Released		

### 5.11. Mounting the drive coupling:

If the drive coupling is supplied by ATLANTA, it will usually be enclosed separately.



Mount and fix the coupling as described in the enclosed operating and mounting instructions of the coupling manufacturer.



When used in areas with explosion hazard, only couplings meeting the ATEX requirements may be used.

**Observe the  references in the operating conditions of the coupling!**

Choosing unsuitable couplings or improper installation may increase the ignition risk.

The maintenance intervals specified in the operating conditions must be strictly observed!

Check for true-running after 10 hours of operation under operating conditions.



Recommended mounting procedure (drawing 5.11.1) :

- Clean all contact surfaces and coat them with a thin oil film before mounting.
- Slide the coupling halfway onto the motor-shaft.
- Tighten the threaded pin of the coupling and secure against loosening (e.g. with Loctite 243) to ensure safe axial locking.
- In the case of standard motors and our drive flanges the motor-shaft is set back by the dimensions "X" (from the table below) compared with the coupling body. In the case of negative dimension „X“, the motor-shaft projects in relation to the coupling body.
- Insert the star and the second coupling half.

Gear unit	Length of motor shaft	Dimension „X“
TS 2	20	1.5
	23	0
TS 5	23	2
	30	-1
TS 10	23	15.5
	30	5
	40	-1.5
TS 25	40	5
	50	-1
	TS 50	40
	50	3
	60	-5
	TS 100	50
	60	-1
	80	-1

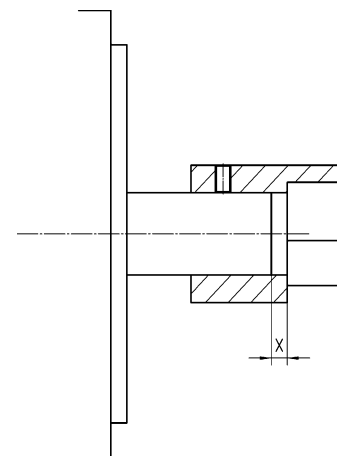

Drawing 5.11.1



# ATLANTA

## Operating and Maintenance Instructions

### BWL 350

### 4100-001-12.93

Dept.	
Rev.Index	
Date	

**TS - Screw Jack Gearbox**  
**Translation from German original**

Page	23	56
Name	Gansemer	2014-04-14
Released		

### 5.12. Mounting the motor:



Mount and attach the motor as described in the enclosed operating and mounting instructions of the motor manufacturer.



When used in areas with explosion hazard, only motors meeting the ATEX requirements may be used.

**Observe the  references in the operating instructions of the motor!**

The choice of unsuitable motors or improper installation may increase the ignition risk.

When used in areas with explosion hazard, use corrosion-protected screws, if there is a risk that mechanical sparking may occur.

When used in areas with explosion hazard, check the threaded pins locking the coupling axially after 10 hours work under operating conditions.



We recommend to proceed as follows:

- Before attaching the motor clean all contact surfaces and coat them with a thin oil film. In order to reduce the danger of fretting corrosion it is also possible to use suitable special grease on the motor-shaft, e.g. Klüberpaste 46MR401
- Optimal centring of the motor is achieved with the motor-shaft arranged vertically downward.
- Slide the motor, fitted with the coupling, onto the input shaft of the screw-jack gearbox in such a way that the coupling nut and the key of the screw-jack gearbox are aligned. (Observe the coupling operating instructions).
- **The motor must slide on easily.**  
There must not be any gap between the motor and the drive flange.  
There must not be any foreign matter on the drive flange.
- If necessary, rotate the motor around the motor axle until the fixing holes of motor and flange coincide.
- Screw motor and drive flange together. Reduced tightening torque acc. to the table below because of aluminium surface. If possible, use washers for improved surface pressure. Choose the length of the screws so that maximum use is made of the available thread depth.
- Tighten the threaded pin of the coupling (not for servo couplings) through the opening in the drive flange and secure against loosening (e.g. Loctite 243) in order to ensure reliable axial locking.
- Secure coupling half on the gear shaft axially. For this purpose tighten the threaded pin through the opening in the motor flange.

Screw size	Strength class of screws	Tightening <sup>*)</sup> torque
M 6	8.8	9 Nm
M 8	8.8	21 Nm
M 10	8.8	42 Nm

<sup>\*)</sup> Use only calibrated torque wrenches! If the tightening torque is too low, the required torque will not be transmitted. If the tightening torque is too high, the screws will be overstrained and become useless. Secure screws against loosening (e.g. with Loctite 243).



# ATLANTA

## Operating and Maintenance Instructions

### BWL 350

### 4100-001-12.93

Dept.		<b>TS - Screw Jack Gearbox</b> <b>Translation from German original</b>	Page	24	56
Rev.Index			Name	Gansemer	2014-04-14
Date			Released		

### 5.13. Mounting the hand wheel

The hand wheel is usually supplied non-mounted.



The hand wheel must either be firmly connected to the input shaft or removed for motor driven operation. The type of connection chosen has to be checked by calculation.



Ensure that no persons may be endangered by a rotating hand wheel.



When used in areas with explosion hazard, it must be ensured that no parts can fall onto or rub against a rotating hand-wheel, in order to avoid overheating, friction or sparking.

### 6. Electrical start-up:



**Only qualified or specially trained personnel may carry out the connection of the electric components. The operating and maintenance instructions of motor and brake must be strictly observed.**



The power and brake connections for direct operation from the mains are shown on the enclosed circuit diagram (paragraph 12 of the instructions).

In order to avoid interference with the brake control, the brake leads must not be laid in the same cable together with clock-pulse controlled power leads.

In order to avoid interference with motor protection devices (temperature sensor, coil thermostats) unshielded supply leads must not be laid in one cable with clock-pulse controlled power leads.



In the case of motors powered by frequency converters the operating and maintenance instructions and the relevant wiring instructions of the converter manufacturer are to be strictly observed.

We recommend to use S-shaped ramps at the converter.



It must be ensured that an overload protection device limits the motor torque to 200 % of the motor torque required for raising the nominal load.

If the motor torque exceeds the torque required for moving the load, this is an indication for additional forces which have not been considered in the design. This reduces the service life of the spindle and the gearbox. In order to avoid this, it is necessary to find out and eliminate the cause of such forces.





# ATLANTA

## BWL 350

### Operating and Maintenance Instructions

### 4100-001-12.93

Dept.	
Rev.Index	
Date	

**TS - Screw Jack Gearbox**  
**Translation from German original**

Page	25	56
Name	Gansemer	2014-04-14
Released		

Determination of the required motor torque from the spindle force:

$$T_M = \frac{F_{Sp} * p}{2 * \pi * \eta_{Sp} * i_G * \eta_G} + T_0$$

- T<sub>M</sub> = required motor torque [in Nm]
- F<sub>Sp</sub> = nominal load of spindle in customer application [in kN]
- p = pitch of the spindle in mm (see table below)
- η<sub>Sp</sub> = spindle efficiency at μ= 0.1 (see table below)
- i<sub>G</sub> = gear ratio (see table below)
- η<sub>G</sub> = efficiency of the gear unit at 1500 rpm (see table below)
- T<sub>0</sub> = idle torque [in Nm] of gear unit depending upon the gear size (see table below)

Gear unit	Spindle pitch	Efficiency of spindle	Gear ratio	Efficiency of gear unit	Idle torque
TS 2 N	4	0.51	5	0.73	0.21
TS 2 L	4	0.51	20	0.45	0.11
TS 5 N	4	0.44	4	0.80	0.10
TS 5 L	4	0.44	16	0.60	0.08
TS 10 N	4	0.41	4	0.84	0.26
TS 10 L	4	0.41	16	0.69	0.16
TS 25 N	6	0.41	6	0.84	0.36
TS 25 L	6	0.41	24	0.69	0.26
TS 50 N	7	0.38	7	0.84	0.76
TS 50 L	7	0.38	28	0.70	0.54
TS 100 N	9	0.34	9	0.79	1.68
TS 100 L	9	0.34	36	0.62	1.02

Example:  
 Gearbox TS 25 with i=6 and trapezoidal-thread spindle Tr30x6  
 Nominal load of spindle in customer application: 13 kN

$$T_M = \frac{13 \text{ kN} * 6 \text{ mm}}{2 * \pi * 0.41 * 6 * 0.84} + 0.36 \text{ Nm} = 6.4 \text{ Nm}$$

The motor torque must not exceed 6.4 kN while moving the load. The overload device must limit the torque during starting (because of the breakaway moment) to 12.8 Nm.



The current consumption of the motor must remain constant over the entire stroke during start-up and operation.  
 Wear or overloading increase the current consumption.

We therefore recommend to measure the current consumption after start-up under rated load and to note this measured value as reference value:

Current consumption after start-up: \_\_\_\_\_ A



# ATLANTA

## BWL 350

### Operating and Maintenance Instructions

### 4100-001-12.93

Dept.		<b>TS - Screw Jack Gearbox</b> <b>Translation from German original</b>	Page	26	56
Rev.Index			Name	Gansemer	2014-04-14
Date			Released		

## 7. Mechanical start-up:



The start-up may only be carried out by qualified or specially trained personnel.

The forces and cycle times that are basis for the layout must not be exceeded, not even during start-up.



Before putting the unit into operation, check whether the layout and the actual loads correspond!



The maximum temperature of the housing must not exceed 80°C in order to keep the thermal stress on shaft seals and lubricant as low as possible.



Caution!

The surface of the gear unit, the spindle and the nut can reach temperatures of more than 65 °C during operation and can cause burns.

The person putting the gear unit into operation must ensure that nobody can be endangered by hot surfaces.



Warning!

Rotating or straight moving parts may catch pieces of clothing, hair and members of the body and injure persons. The person installing the gear unit must ensure that persons cannot be endangered by any rotating or straight moving components.



Monitoring and protective equipment must not be out of service.

When used in areas with explosion hazard, the person putting the screw-jack gearbox into operation must ensure that the surface temperature of 65°C is not exceeded on any of the components. If necessary, he must control the surface temperature.



He must furthermore ensure that no sparking can occur. Rotating or straight moving parts and those with which they may come into contact are to be protected against corrosion (e.g. by greasing, painting, zinc coating or the like).



# ATLANTA

## BWL 350

### Operating and Maintenance Instructions

### 4100-001-12.93

Dept.	
Rev.Index	
Date	

**TS - Screw Jack Gearbox**  
**Translation from German original**

Page	27	56
Name	Gansemer	2014-04-14
Released		

#### 7.1. Lubricating instructions for screw-jack gearboxes:

The basic gear unit is delivered filled with fluid grease and ready for operation.  
 For oil change instructions see para. 9.3.

Sliding friction occurs between trapezoidal-thread spindle and nut. Therefore these components must be adequately lubricated. Without proper lubrication there will be increased wear leading to the destruction of the nut.



The trapezoidal-thread spindle is supplied with lubrication sufficient for approx. 10 strokes. The grease film on the spindle must not be contaminated. If it is, clean the spindle before the first operation and coat it with a new grease film.



Optimal lubrication is achieved with our electronically controlled lubricator supplying the lubricant continuously. If used only seldom, manual lubrication may be sufficient. In the case of long intervals, however, this may lead to increased wear of the nut. As suitable lubricants we recommend high-grade adhesive grease to be applied with a brush in the case of manual lubrication.

Recommended grease:

- Klüber: Microlube GB-0
- Texaco: Molytex EP 2
- Mobil: Mobilgrease HP
- Esso: Beacon EP 2
- Shell: Gadus S2 V100 2

ATLANTA order code for 1 kg Klüber Microlube GB-0: 65 90 002



The electronically controlled lubricator should be taken in operation as described in the enclosed instructions BKI 102.

For start-up fill the hose by means of a grease gun before mounting. Proper lubrication is ensured only when the connecting hose is completely filled with grease right into the nut. For the pressure build-up observe the times mentioned in the grease-cup instructions. Fastest pressure build-up: all switches in „ON“ position: Pressure build-up within 6-8 hours.  
 Type of lubricant: Microlube GB0 (Fa. Klüber)

Based on experiments we recommend to set an emptying time of 6 months after start-up and pressure build-up. Within the first few days and weeks of operation the grease supply should be checked at regular intervals and the emptying time adjusted to the actual application. The spindle surface should always be covered with a uniformly thin grease coating. Grease in the protective tube or under the bellows is an indication of excessive supply of lubricant. Screeching noises between spindle and nut indicate insufficient lubricant supply.



**The non-observance of these lubricating instructions leads to the dismissal of possible warranty claims.**



# ATLANTA

## Operating and Maintenance Instructions

### BWL 350

### 4100-001-12.93

Dept.	
Rev.Index	
Date	

**TS - Screw Jack Gearbox**  
**Translation from German original**

Page	28	56
Name	Gansemer	2014-04-14
Released		

### 7.2. Test run of the screw-jack gearbox before installation:



Before starting the test run, the gear unit must be secured against torsion and the torque must be supported by suitable measures at the following points:

Gear units with non-rotating spindle:

At the fixing flange, fork link, spherical plain bearing rod head or swivel head.

Gear units with torsion protection inside the protective tube are protected internally against twisting of the spindle.

Gear units with rotating spindle:

At the running nut.

Move spindle/nut by hand to a medium stroke position.

Perform one full stroke by hand or with the motor. Switch off in time before reaching the end positions.

Do not exceed the maximum extended end position nor fall below the minimum retracted end position. The values  $L_{min}$  and  $L_{max}$  are noted on a nameplate at the screw-jack gearbox

**$L_{min}$  = minimum length in retracted position (do not fall below)**

**$L_{max}$  = maximum length in extended position (do not exceed).**



When starting the motor for the first time, the gear unit must not be in an end position, since otherwise the gear unit will hit the block thus damaging components should the motor turn into the wrong direction.



# ATLANTA

## Operating and Maintenance Instructions

### BWL 350

### 4100-001-12.93

Dept.	
Rev.Index	
Date	

**TS - Screw Jack Gearbox**  
**Translation from German original**

Page	29	56
Name	Gansemer	2014-04-14
Released		

Drawing 7.2.1 End positions for gear units with rotating spindle:

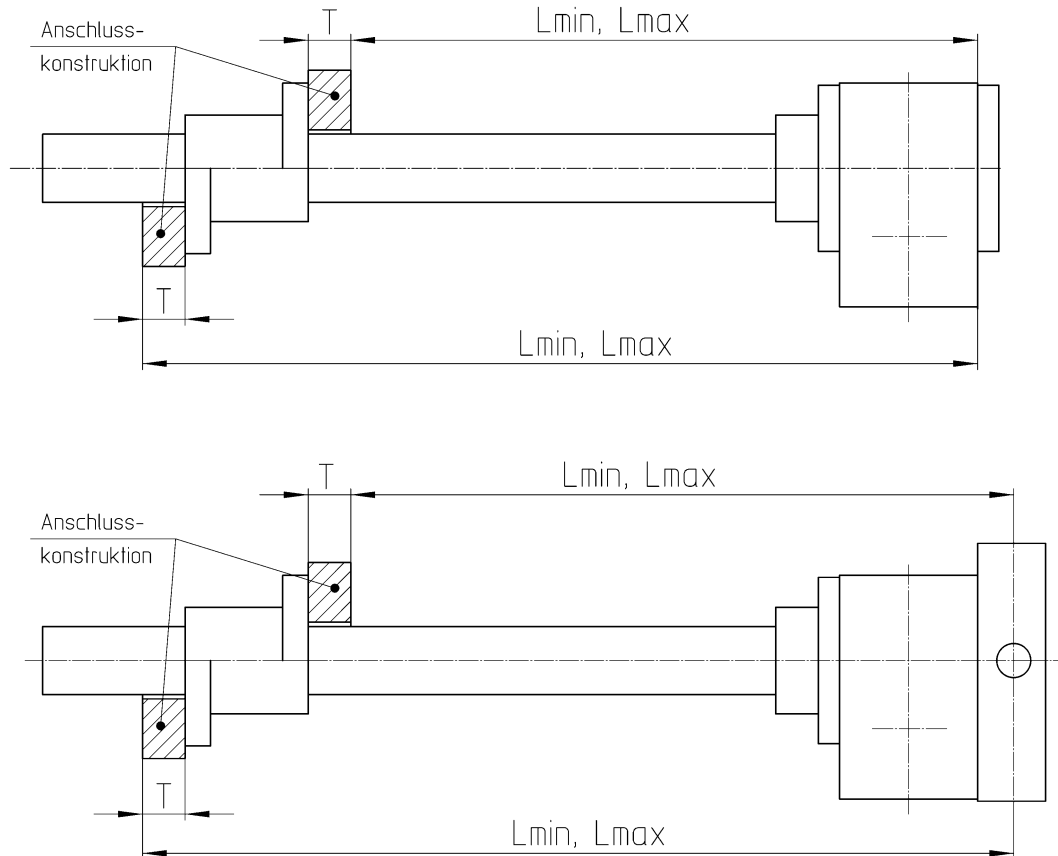

Anschlusskonstruktion = following construction

Post the nameplate easily visible near the gear unit.

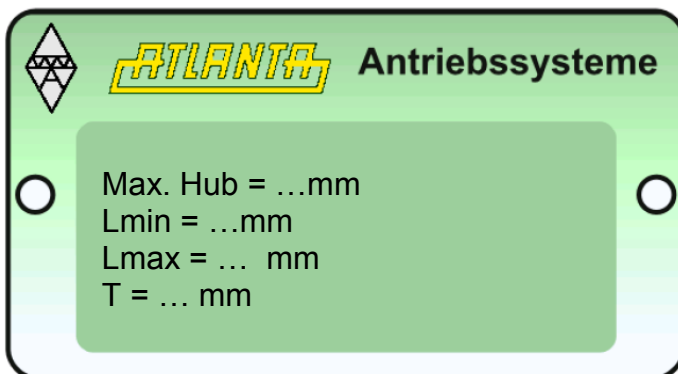

T = the thickness of the following construction on which the design is based.



# ATLANTA

## Operating and Maintenance Instructions

### BWL 350

### 4100-001-12.93

Dept.	
Rev.Index	
Date	

**TS - Screw Jack Gearbox**  
**Translation from German original**

Page	30	56
Name	Gansemer	2014-04-14
Released		

Drawing 7.2.2. End positions for gear units with non-rotating spindle:

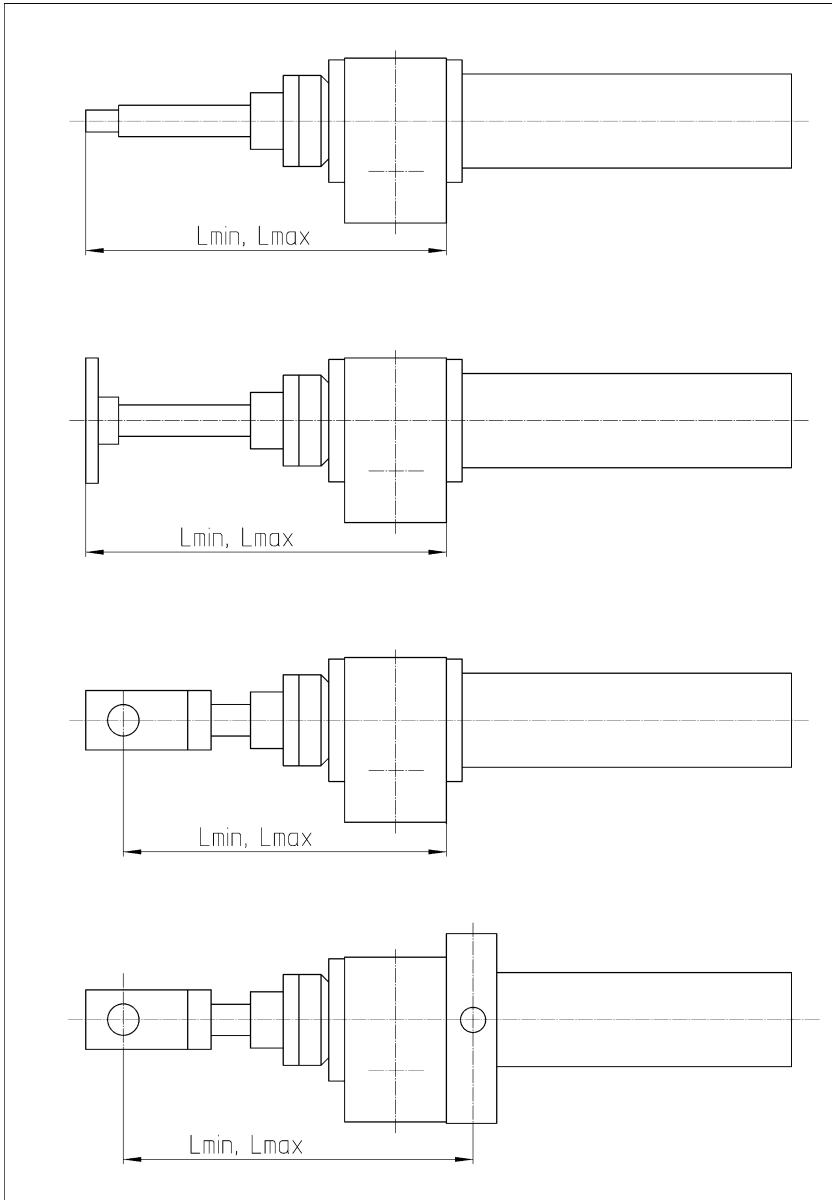

**ATLANTA Antriebssysteme**

Max. stroke = ...mm  
Lmin = ...mm  
Lmax = ... mm



# ATLANTA

## BWL 350

### Operating and Maintenance Instructions

### 4100-001-12.93

Dept.		<b>TS - Screw Jack Gearbox</b> <b>Translation from German original</b>	Page	31	56
Rev.Index			Name	Gansemer	2014-04-14
Date			Released		

### 7.3. Installation of screw-jack gearbox in the system:



There are two machined mounting surfaces with sufficiently dimensioned fixing holes and threaded holes.

Choose the length of the screws so that maximum use is made of the thread depth. Choose the installation, if possible, in such a way that the flow of forces passes over the supporting surface and not over the screws.

In swivelling drives the swivel bolts must be parallel in order to avoid adverse tensions.



Ensure tension-free mounting.

Use all threaded holes of the appropriate connecting surface.

Tighten the screws with the required tightening torque (see table below).



Spindle and nut must be perfectly aligned when installed. Lateral forces or bending stresses are unacceptable. They lead to increased wear and reduced service life.

Lateral forces, if any, must not exceed 1 % of the nominal force of the gear unit.

Example: TS25

Nominal force: 25 kN

Max. allowable transverse force: 250 N



The alignment between spindle and nut must be carefully checked in order to exclude overheating of the spindle drive. This check has to be repeated after 10 hours work under operating conditions.



Additional attachments or alterations at the gear unit require written permission by ATLANTA.



It must be ensured that no persons are endangered by the free rotating input-shaft end. The covering cap for the second shaft end ensures reliable protection.



Before starting the operation, the usable range of the spindle must be carefully greased. Observe the lubrication instructions of para. 7.1.



When used in areas with explosion hazard, it must be ensured that no parts can fall onto or rub against the free input-shaft end in order to avoid overheating, friction or sparking.

A firm cover ensures reliable protection.



When used in areas with explosion hazard, suitable corrosion protection (e.g. greasing, painting, zinc coating) must be provided, if there is a risk that mechanical sparking may occur.

Also corrosion protected screws have to be used.



# ATLANTA

## Operating and Maintenance Instructions

### BWL 350

### 4100-001-12.93

Dept.	
Rev.Index	
Date	

**TS - Screw Jack Gearbox**  
**Translation from German original**

Page	32	56
Name	Gansemer	2014-04-14
Released		

Gear unit	Screw size	Depth of thread [mm]	Strength class of the screws	Tightening <sup>*)</sup> torque
TS 2	M 6	12	8.8	10 Nm
TS 5	M 8	12	8.8	20 Nm
TS 10	M 8	15	8.8	25 Nm
TS 25	M 10	15	8.8	40 Nm
TS 50	M 12	17	8.8	70 Nm
TS 100	M 16	26	8.8	180 Nm

<sup>\*)</sup> Use only calibrated torque wrenches! If the tightening torque is too low, the required torque will not be transmitted. If the tightening torque is too high, the screws will be overstrained and become useless. Secure screws against loosening (e.g. with Loctite 243).

Material under the screw heads: Steel with boundary surface pressure > 500 N/mm<sup>2</sup>

#### 7.4. Installation of screw-jack gearbox with non-rotating spindle in the system:



**Rotating or straight moving parts may catch pieces of clothing, hair and members of the body and injure persons. It must be ensured that persons cannot be endangered by any rotating or straight moving components during the installation.**



The loads, travelling speeds and duty cycles on which the layout is based must not be exceeded, not even during start-up operation  
**Exceeding the lifting force or the duty cycle even only once may already cause permanent damage!**



Trapezoidal-thread drives are statically self-locking. The self-locking feature can be partially or fully neutralized by vibrations. An additional holding device (e.g. motor brake) is required.



**For systems comprising several screw jacks also observe paragraph 7.6 !**



The screw-jack gearbox may be subjected only to axial loads. Radial loads and bending moments must be avoided. It must be mounted free of tensions and transverse forces.

Lateral forces and bending stresses reduce the service life considerably.



**Systems with guiding devices:**

Attach the screw-jack gearbox as described in paragraph 7.3.  
 The spindle must be adjusted parallel to the guiding device.  
 In the case of swivel drives double-cardanic suspension must be provided.



**Systems without guiding devices:**

Attach the screw-jack gearbox as described in paragraph 7.3.  
 Ensure that no lateral forces and bending moments act upon the spindle (max. transverse force value = 1% of the nominal force of the gear unit).  
 In the case of swivel drives double-cardanic suspension must be provided.





# ATLANTA

## BWL 350

### Operating and Maintenance Instructions

### 4100-001-12.93

Dept.	
Rev.Index	
Date	

**TS - Screw Jack Gearbox**  
**Translation from German original**

Page	33	56
Name	Gansemer	2014-04-14
Released		

Attach the spindle end with the mounting flange, fork link, spherical plain bearing rod head or swivel head to the part to be moved. Insert the screws at the flange only loosely, do not tighten them.



When operating the unit for the first time, perform one full lifting stroke. In order to avoid damage we recommend to perform the first lifting stroke manually.

In the case of motor-driven displacement it is important to stop before reaching the end positions and to approach them in inching mode in order to avoid damage due to wrong adjustments. See paragraph 7.2.

Check the limit switch for correct position and exact switching function.

Check the ventilation of the bellows while moving the unit under operating conditions.

After mounting check the bellows for proper attachment and functioning.

In retracted position it must not be compressed too firmly. It must not rub against any rotating components.

In extended position it must not be overstretched. The folds must not dent in.

Use all available supporting rings. Make sure that the bellows does not touch the spindle.

When all connection parameters are met, perform several lifting strokes without load.

Make sure that the spindle moves easily and that there are no tensions (uniform power drain).

Tighten the screws at the mounting flange with the required torque (see table below).

Then perform one or two lifting cycles under load. Check once more for easy and smooth motion and uniform power drain.



Increased noise, unwieldy transmission and consequently increased power drain are an indication for wear. We recommend to measure the power drain after start-up and to note this value in paragraph 6 as a reference value.



When used in areas with explosion hazard, suitable corrosion protection (e.g. greasing, painting, zinc coating) must be provided, if there is a risk that mechanical sparking may occur. Also corrosion protected screws have to be used.

Gear unit	Size of screws	Strength class of screws	Tightening <sup>*)</sup> torque
TS 2	M 5	8.8	5.9 Nm
TS 5	M 8	8.8	25 Nm
TS 10	M 10	8.8	48 Nm
TS 25	M 10	8.8	48 Nm
TS 50	M 12	8.8	84 Nm
TS 100	M 16	8.8	205 Nm

<sup>\*)</sup> Use only calibrated torque wrenches! If the tightening torque is too low, the required torque will not be transmitted. If the tightening torque is too high, the screws will be overstrained and become useless. Secure screws against loosening (e.g. with Loctite 243).



# ATLANTA

## Operating and Maintenance Instructions

### BWL 350

### 4100-001-12.93

Dept.	
Rev.Index	
Date	

### TS - Screw Jack Gearbox

Translation from German original

Page	34	56
Name	Gansemer	2014-04-14
Released		

### 7.5. Installation of the screw-jack gearbox with rotating spindle in the system:



Rotating or in linear direction moving may catch pieces of clothing, hair and members of the body. Take care during installation that persons cannot be endangered by parts moving in linear directions.



The loads, travelling speeds and duty cycles for which the unit is laid out must not be exceeded - not even during the installation.

**Exceeding the lifting force or the duty cycle even only once may already cause permanent damage!**



Trapezoidal-thread drives are statically self-locking. The self-locking feature can be partially or fully neutralized by vibrations. An additional holding device (e.g. motor brake) is required.



For **systems comprising several screw jacks** also observe paragraph 7.6 !



The screw-jack gearbox may only be subject to axial loads. Radial loads or bending moments are to be avoided. It must be mounted free of tensions and transverse forces.

Lateral forces and bending stresses reduce the service life considerably.

Max. transverse force value = 1% of the nominal force of the gear unit



#### **Systems with guiding devices:**

Attach the screw-jack gearbox as described in paragraph 7.3.

The spindle must be adjusted parallel to the guiding device.

In the case of swivel drives double-cardanic suspension must be provided.



#### **Systems without guiding devices:**

Use only screw-jack gearboxes with short spindles requiring no mating bearing flange.

To be used only with tensile loads. Compressive loads without guiding devices lead to increased wear and tear of the nut.

Attach the screw-jack gearbox as described in paragraph 7.3.

Ensure that no lateral forces and bending moments act upon the spindle.

(Max. transverse force value = 1% of the nominal force of the gear unit)

In the case of swivelling drives double-cardanic suspension must be provided.



# ATLANTA

## Operating and Maintenance Instructions

# BWL 350

## 4100-001-12.93

Dept.	
Rev.Index	
Date	

**TS - Screw Jack Gearbox**  
**Translation from German original**

Page	35	56
Name	Gansemer	2014-04-14
Released		

### Mounting the bellows (see paragraph 5.7):

Mount the spindle nut observing para. 5.3. Mount the nut on the attachment without tension. Fasten the bellows with a hose clamp on the spindle nut. Make sure it is not twisted. Then fasten the second bellows in the same way between the attachment and the spindle end.

The bellows must always be attached to non-rotating parts.

After mounting, check the bellows for proper functioning:

In retracted position it must not be compressed too firmly. It must not rub against any rotating components.

In extended position it must not be overstretched. The folds must not dent in.

Use all available supporting rings. Check that bellows are not in contact with the spindle.

Check the ventilation of the bellows during the lifting operation under operation conditions.



When operating the unit for the first time, perform one full lifting stroke.

In order to avoid damage we recommend to perform the first lifting stroke manually.

In the case of motor-driven displacement it is important to stop before reaching the end positions and to move up to them in inching mode in order to avoid damage due to wrong adjustments. See paragraph 7.2.

Operate the drive unit **without** load so that the spindle nut is moved to the end position close to the gearbox. Tighten the screw nuts only slightly.

Move to the other end position. Check that the nut moves easily and smoothly on the spindle and that no tensions occur (uniform power drain). The spindle end must not beat during the traversing operation.

If provided, fix the mating bearing flange supporting the spindle end in the end position away from the gearbox. Tighten the screws only slightly.

Move back to the other end position and check for free motion.

In the end position close to the gearbox tighten the screw nuts with the specified tightening torque (see table). Use washers because of allowable surface pressure of bronze.

Move to the other end position. Check again for free and smooth motion.

Tighten the screws of the mating bearing flange with the specified tightening torque (acc. to table below).

Perform once more one or two cycles without load in order to exclude tensions.

Then perform one or two cycles with load. Check again for easy and smooth motion and uniform power drain.



Increased noise, unwieldy transmission and consequently increased current consumption are an indication for wear. We recommend to measure the current consumption after the start-up and to note this value as a reference value in paragraph 6.



# ATLANTA

## BWL 350

### Operating and Maintenance Instructions

### 4100-001-12.93

Dept.	
Rev.Index	
Date	

**TS - Screw Jack Gearbox**  
**Translation from German original**

Page	36	56
Name	Gansemer	2014-04-14
Released		



When used in areas with explosion hazard, suitable corrosion protection (e.g. greasing, painting, zinc coating) must be provided, if there is a risk that mechanical sparking may occur. Also corrosion protected screws have to be used.

Trapezoidal nut	Screw size	Strength class of screws	Tightening <sup>)</sup> torque
87 14 002 + 600	M 5	8.8	5.9 Nm
87 18 003 + 600			
87 20 004 + 600	M 6	8.8	10 Nm
87 30 015			
87 30 600	M 8	8.8	25 Nm
87 40 006			
87 40 600	M 10	8.8	48 Nm
87 60 007 + 600	M 12	8.8	84 Nm

Mating bearing flange	Screw size	Strength class of screws	Tightening <sup>)</sup> torque
60 22 500	M 8	8.8	25 Nm
60 23 500			
60 24 500	M 10	8.8	48 Nm
60 25 500			
60 26 500	M 12	8.8	84 Nm
60 27 500	M 20	8.8	415 Nm

<sup>)</sup> Use only calibrated torque wrenches! If the tightening torque is too low, the required torque will not be transmitted. If the tightening torque is too high, the screws will be overstrained and become useless. Secure screws against loosening (e.g. with Loctite 243).



# ATLANTA

## Operating and Maintenance Instructions

# BWL 350

## 4100-001-12.93

Dept.		<b>TS - Screw Jack Gearbox</b> <b>Translation from German original</b>	Page	37	56
Rev.Index			Name	Gansemer	2014-04-14
Date			Released		

### 7.6. Screw-jack lifting systems comprising several gearboxes:



When systems consist of several screw-jack gearboxes, the components where the adjacent attachment is to be fastened must be carefully adjusted in height so that the gearboxes will be uniformly loaded and no tensions occur.

Our universal shafts are torsionally rigid, fail-proof, free of play and wear, at the same time being elastic and axially and angularly flexible. No maintenance required. They dampen noise, torsional vibrations and shocks.

The center part can be removed without having to shift the gearboxes. Just remove the screws item 5. See sect. 7.6.1 and 7.6.2.

The plastic elements are oil-resistant.



The universal shafts are not permitted for areas with explosion hazard.



If, according to the applicable accident prevention regulations the shaft must be provided with a cover, this cover must be made from solid steel parts. Adequate ventilation of the universal shaft must be ensured.

The cover is not included in the scope of delivery.



Aligning the universal shaft:

In order to achieve a long service life, the gearboxes should be installed and aligned as carefully as possible. This applies especially in the case of high speeds.

The total displacement is a combination of radial and angular misalignment.

Permissible radial displacement:

The permissible radial displacement is equal to an angle of 0.15°.

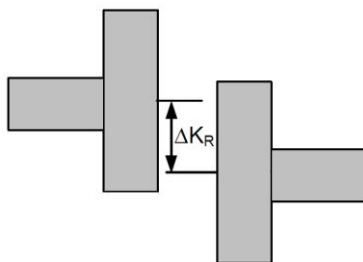



# ATLANTA

Operating and Maintenance Instructions

## BWL 350

### 4100-001-12.93

Dept.	
Rev.Index	
Date	

### TS - Screw Jack Gearbox Translation from German original

Page	38	56
Name	Gansemer	2014-04-14
Released		

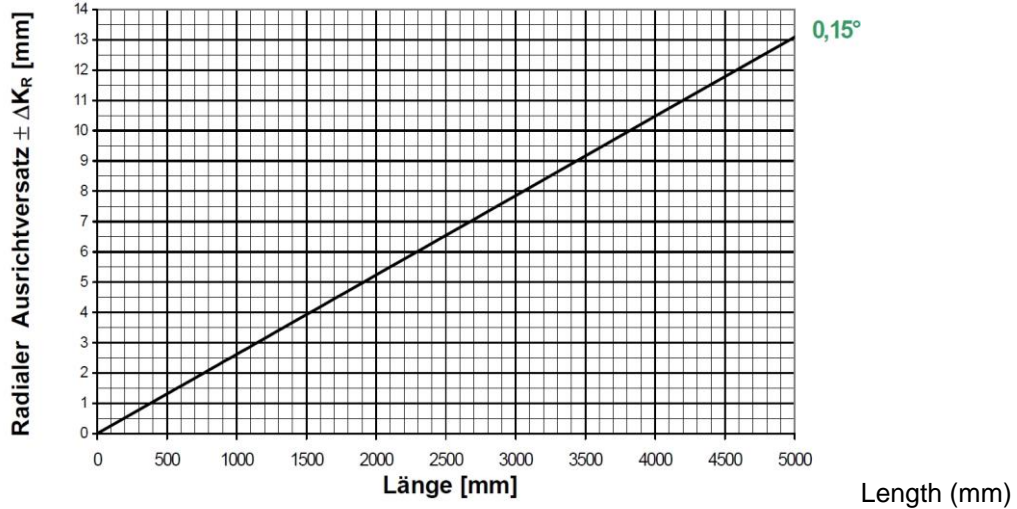

Permissible angular displacement:

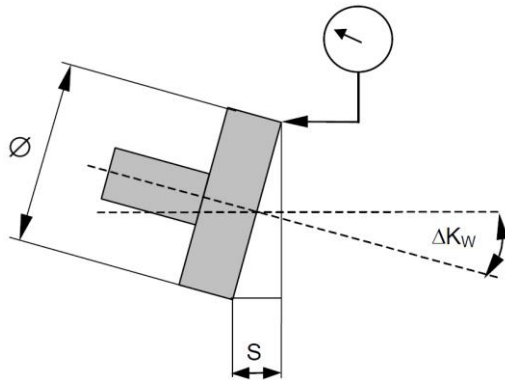

The angular displacement must be checked at each flange. The deviation S must not exceed the following value:

$$S \leq 0.0026 \cdot \varnothing$$

Universal shaft	Flange diameter $\varnothing$	Max. angular displacement S
60 83 30x	56	0.146
60 83 40x	85	0.221
60 83 45x	100	0.260
60 83 60x	120	0.312



# ATLANTA

## BWL 350

### Operating and Maintenance Instructions

### 4100-001-12.93

Dept.		<b>TS - Screw Jack Gearbox</b> <b>Translation from German original</b>	Page	39	56
Rev.Index			Name	Gansemer	2014-04-14
Date			Released		

#### 7.7.1 Mounting the universal shaft with key connection (60 83 x0x):



This universal shaft has a bore with keyway on both flanges.

The relative positions of the keyways can be varied by the screws items 3 / 5.

For gear units with non-rotating spindle, this can lead at the worst to a max. difference in height of 0.25 mm between the attachments spindle (with torsion protection 0.5 mm) . In the case of gear units with rotating spindle the difference will be 0.08 mm at the worst.

If this is not sufficient, it is possible to use the shafts 60 83 x1x with clamp connection.

In the case of gearboxes with rotating spindle and gearboxes with non-rotating spindle and connecting flange, precise alignment can also be achieved by not cutting the fixing threads in advance but only after the alignment.

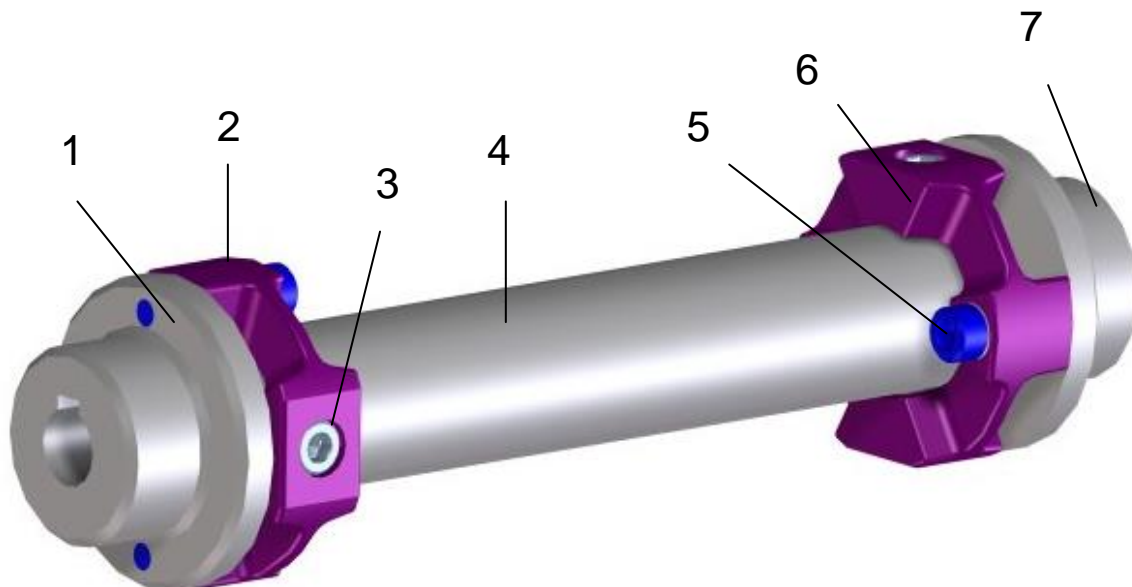

#### Instructions for installing the screws:

Put some grease under the screw heads so that the screw head slides on the aluminum bushing and the bushing does not twist inside the plastic elements item 2/item 6.

If necessary, prevent the elastic element from twisting/skewing while tightening the screws by applying counter-pressure with a suitable tool. This is particularly important at the screws item 3, so that the annular surface between the elastic element item 2 and the tube item 4 is in full contact and does not support only at 2 edges. This might cause the screw to come loose so that the coupling may be destroyed.

Use only the screws supplied with colored adhesive compound in the thread (e.g. blue)! This micro-capsulated adhesive makes the screw stick inside the thread thus securing it reliably against coming loose. The curing time of the adhesive after screwing is about 4-5 hours at 20°C. The coupling must not be operated before. Higher temperatures accelerate the curing process. At a temperature of 70°C (e.g. heating with warm-air blower) it takes only approx. 15 minutes. The adhesive is resistant to temperatures between -80° and +90°C.

The adhesive is cured completely after 24 hours. Only then, you should subject the universal shaft to the full torque.

Adhesive, possibly stripped off from the thread while screwing in, may stick between hub and



# ATLANTA

## BWL 350

### Operating and Maintenance Instructions

### 4100-001-12.93

Dept.	
Rev.Index	
Date	

**TS - Screw Jack Gearbox**  
**Translation from German original**

Page	40	56
Name	Gansemer	2014-04-14
Released		

the aluminum bushings thus increasing the frictional application pressure between these parts.

Anaerobic adhesives (such as Loctite, Omnifit etc.) undo the adhesion of the rubber on the metal thus leading to the destruction of the shaft. We therefore advise you against their use. Rubber parts damaged or destroyed by unsuitable adhesives do not justify a claim for damages

Universal shaft	Screw size radial / item 3	Screw size axial / item 5	Tightening- <sup>*)</sup> torque
60 83 30x	M 6x10	M 6x25	10 Nm
60 83 40x	M 8x20	M 8x20	25 Nm
60 83 45x	M 8x25	M 8x25	25 Nm
60 83 60x	M 10x30	M 10x30	50 Nm

<sup>\*)</sup> Use only calibrated torque wrenches! If the tightening torque is too low, the required torque will not be transmitted. If the tightening torque is too high, the screws will be overstrained and become useless.

**Mounting the universal shaft:**

Slide the hubs items 1 and 7 onto the gear shafts.  
 Check the angular displacement.  
 Check the radial displacement between the two hubs. Align the gear unit.

If pillow-block bearings are used they should now be mounted according to para. 7.6.3. Arrange the pillow-block bearing in the middle. Should there be several pillow-block bearings, distribute them evenly spaced on the tube length.

Slide the elastic elements item 2 and item 6 on the tube item 4 and fix them with screws item 3. Observe the instructions above.  
 Screw together the hub item 1 with the elastic element item 2 using the screws item 5.

**Gear units with non-rotating spindle:**

Adjust fixing flanges, fork links, swivel heads or spherical plain bearing rod heads to equal height.

**Gear units with rotating spindle:**

Align flange nuts to same height.

Screw up the elastic element item 6 with the nearest thread in item 7. This results in a height difference of the connecting components.

If the difference is too big for your application, adjust the connecting components once more to equal height and cut the threads for the mounting flange or the flange nut in the attachment device in this position.

Rotate the universal shaft by hand and align the pillow-block bearings so that the universal shaft is not subject to tensional stress.

Slightly tighten the screws on the gearboxes and pillow-block bearings. Then rotate the universal shaft once more by hand. If it rotates smoothly, tighten the screws completely.

Tightening torques for fastening the gearboxes are listed in paragraph 7.3.

Position the universal shaft axially in the middle between the gearboxes. Tighten the threaded pin in the hub in order to fix the universal shaft axially.





# ATLANTA

## BWL 350

### Operating and Maintenance Instructions

### 4100-001-12.93

Dept.	
Rev.Index	
Date	

**TS - Screw Jack Gearbox**  
**Translation from German original**

Page	41	56
Name	Gansemer	2014-04-14
Released		

#### **7.7.2 Mounting the universal shaft with clamped connection (60 83 x1x):**



One flange of this universal shaft has a bore with keyway and the other one a smooth bore with clamping hub and screw.

It can therefore be mounted, when the attachments are aligned to the same height, without risking a deviation.

It is suitable for all gearboxes and attachments.

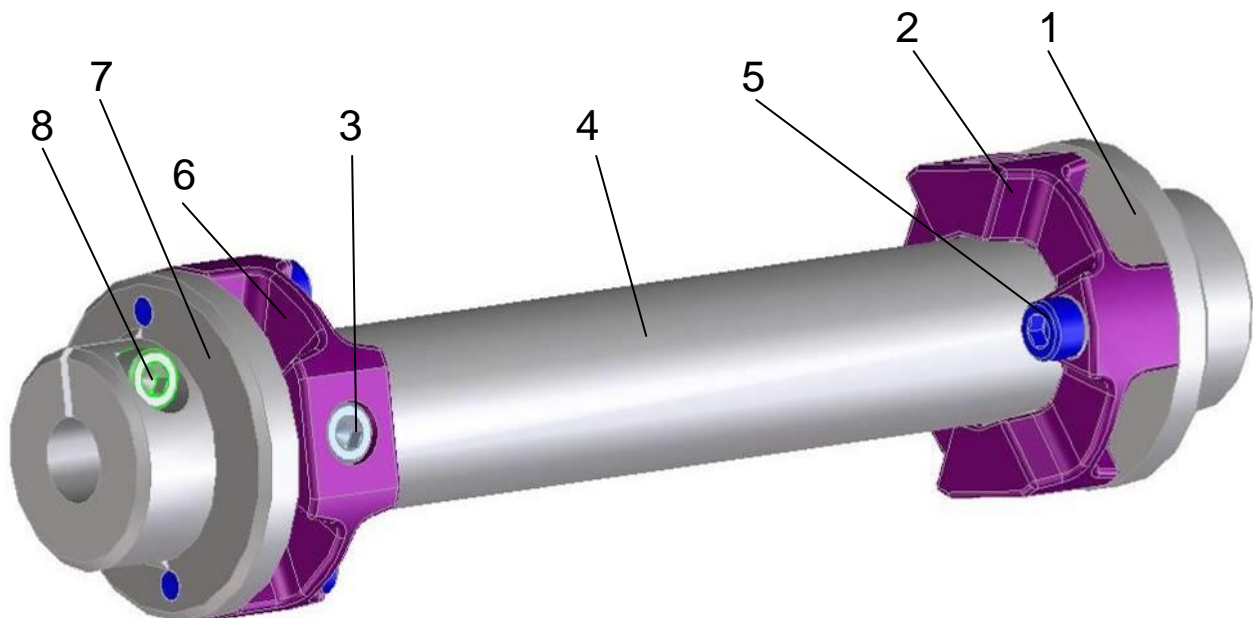

#### **Instructions for installing the screws:**

Put some grease under the screw heads so that the screw head slides on the aluminum bushing and the bushing does not twist inside the plastic elements item 2/ item 6.

If necessary, prevent the elastic element from twisting/skewing while tightening the screws by applying counter-pressure with a suitable tool. This is particularly important at the screws item 3, so that the annular area between the elastic element item 2 and the tube item 4 is in full contact and does not support only at 2 edges. This might cause the screw to come loose and the coupling to be destroyed.

Use only the screws supplied with colored adhesive compound in the thread (e.g. blue)! This micro-capsulated adhesive makes the screw stick inside the thread thus securing it reliably against coming loose. The curing time of the adhesive after screwing is about 4-5 hours at 20°C. The shaft must not be operated before. Higher temperatures accelerate the curing process. At a temperature of 70°C (e.g. heating with warm-air blower) it takes only approx. 15 minutes. The adhesive is resistant to temperatures between -80° and +90°C.

The adhesive is cured completely after 24 hours. Only then, you should subject the universal shaft to full torque.

Adhesive, possibly stripped off from the thread while screwing in, may stick between hub and the aluminum bushings thus increasing the frictional application pressure between these parts.



# ATLANTA

## BWL 350

### Operating and Maintenance Instructions

### 4100-001-12.93

Dept.	
Rev.Index	
Date	

**TS - Screw Jack Gearbox**  
**Translation from German original**

Page	42	56
Name	Gansemer	2014-04-14
Released		

Anaerobic adhesives (such as Loctite, Omnifit etc.) undo the adhesion of the rubber on the metal thus leading to the destruction of the coupling. We therefore advise you against their use. Rubber parts damaged or destroyed by unsuitable adhesives do not justify a claim for damages

Universal shaft	Screw size radial / item 3	Screw size axial / item 5	Tightening- <sup>*)</sup> torque
60 83 30x	M 6x10	M 6x25	10 Nm
60 83 40x	M 8x20	M 8x20	25 Nm
60 83 45x	M 8x25	M 8x25	25 Nm
60 83 60x	M 10x30	M 10x30	50 Nm

<sup>\*)</sup> Use only calibrated torque wrenches! If the tightening torque is too low, the required torque will not be transmitted. If the tightening torque is too high, the screws will be overstrained and become useless.

**Mounting the universal shaft:**

Slide the hubs item 1 and item 7 onto the gearbox shafts. Tighten the clamping screw item 8 in order to achieve proper centering.  
 Check the angular displacement.  
 Check the radial displacement between both hubs. Align the gear unit.

If pillow-block bearings are used they should be mounted now according to paragraph 7.6.3. Arrange the pillow-block bearing in the middle. If there are several pillow-block bearings, distribute them evenly spaced on the pipe length.

Slide the elastic elements item 2 and item 6 onto the tube item 4 and fix with screws item 3. Observe the instructions above.  
 Screw together the hub item 1 and the elastic element item 2 using the screws item 5.  
 Loosen the clamping screw item 8 again.  
 Screw together the elastic element item 6 and the hub item 7.

**Gear units with non-rotating spindle:**

Align fork links, link rod heads, swivel heads, or fixing flanges to same height.

**Gear units with rotating spindle:**

Align flange nuts to same height.

Position the universal shaft axially in the middle between the gear units.

Tighten the clamping screw item 8 hand-tight.

Rotate the universal shaft by hand and align the pillow-block bearings so that the universal shaft is not subject to tensional stress.

Slightly tighten the screws on the gearboxes and pillow-block bearings. Then rotate the universal shaft once more by hand. If it rotates smoothly, tighten the screws completely.

Tightening torques of the clamping screws item 8 are the same as for the screws item 3. See table above.

For tightening torques for fixing the gearbox see paragraph 7.3.

Tighten the threaded pin in hub item 1 in order to fix the universal shaft axially.



# ATLANTA

## Operating and Maintenance Instructions

### BWL 350

### 4100-001-12.93

Dept.	
Rev.Index	
Date	

**TS - Screw Jack Gearbox**  
**Translation from German original**

Page	43	56
Name	Gansemer	2014-04-14
Released		

### 7.6.3 Mounting the pillow blocks:



Use only pillow blocks with bearings on clamping sleeves. Only this type of fastening will avoid the eccentric fixing of the universal shaft.

**Preparation:**

Bolting surfaces: Clean before mounting. Roughness  $\leq 12.5 \mu\text{m}$ . Smoothness within IT7. Check tube for dimensional and shape accuracy. Diameter tolerance: h10

**Mounting:**

Position the housing in the correct place along the linkage shaft and fix it with screws on the bolting surface. Tighten the screws only hand-tight. .

Insert rubber cords in the grooves of the bottom part of the housing.

Place one half each of the aluminum split ring, with felt seal fitted, on the rubber cords.



Slide the bearing with the clamping sleeve onto the tube. The nut must be in the housing on the side where there is **no** grease nipple so that the bearing can be re-lubricated during operation.

Fill the bearing completely with the appropriate grease. The rest of the recommended amount of grease is to be filled laterally into the lower housing portion.

Pillow block	Amount of grease for first filling	Connecting screws 8.8 for both pillow block halves and tightening torque <sup>)</sup>		Fixing screws 8.8 and tightening torque <sup>)</sup>	
60 85 300	50 g	M10x50	50 Nm	M12	80 Nm
60 85 400	65 g	M10x50	50 Nm	M12	80 Nm
60 85 450	75 g	M10x55	50 Nm	M12	80 Nm
60 85 600	180 g	M12x65	80 Nm	M16	200 Nm

<sup>)</sup> Use only calibrated torque wrenches! If the tightening torque is too low, the required torque will not be transmitted. If the tightening torque is too high, the screws will be overstrained and become useless. Secure screws against loosening.

Install the universal shaft with bearing in the bottom part of the housing.

Align the shaft and the pillow block housing carefully in relation to the gearboxes. The notches in the ends of the housing feet may be helpful. Then tighten the fixing screws slightly.

Insert the rubber cords in the grooves on the upper part of the housing.

Fit the seal halves on the cords.

Fit the upper part of the housing. Pay attention that the markings on the upper and the lower part match as the parts are not interchangeable.

Tighten the connecting screws with the tightening torque mentioned above.

Upon final alignment of the universal shaft according to paragraphs 7.6.1. or 7.6.2. tighten the fixing screws with the tightening torque listed above. .



# ATLANTA

## BWL 350

### Operating and Maintenance Instructions

### 4100-001-12.93

Dept.	
Rev.Index	
Date	

**TS - Screw Jack Gearbox**  
**Translation from German original**

Page	44	56
Name	Gansemer	2014-04-14
Released		

## 8. Operation



Forces, cycle times, torque or any other relevant working conditions on which the layout is based, must not be exceeded during the practical operation – not even for a short time.

Exceeding the limits even only once can already cause permanent damage.

It must be assured that the layout and the actual loads are in conformity with each other!



If the gearboxes are lubricated with the standard lubricants, the ambient temperature must lie between  $-10^{\circ}\text{C}$  and  $+40^{\circ}\text{C}$ .

Deviating temperatures require special lubricants. Please consult us.

It must be ensured that adequate dissipation of the generated heat is provided for.



An absolute temperature of  $80^{\circ}\text{C}$  on the surface of the housing must not be exceeded in order to keep the thermal stress on shaft seals and lubricant as low as possible, which has a positive effect upon their service life .



When used in areas with explosion hazard, the operator must take care that the surface temperature of  $65^{\circ}\text{C}$  is not exceeded on any of the components.

If necessary, he must control the surface temperature.

In order to find out which of the components heats up most, the temperature should be measured under operating conditions.

The operator must furthermore ensure that no sparking can occur. Rotating or straight moving parts and parts which could come into contact with these, must be protected against corrosion (e.g. by greasing, painting, zinc coating).



**Caution!**

The surface of the gear unit, the spindle and the nut can reach temperatures of more than  $65^{\circ}\text{C}$  during operation and can cause burns.

The person putting the gear unit into operation must ensure that nobody can be endangered by hot surfaces.



**Warning!**

Rotating or straight moving parts may catch pieces of clothing, hair and members of the body and injure persons. The person operating the gear unit must ensure that persons cannot be endangered by any rotating or straight moving components.



Monitoring and protective equipment must not be put out of operation.



# ATLANTA

## BWL 350

### Operating and Maintenance Instructions

### 4100-001-12.93

Dept.	
Rev.Index	
Date	

**TS - Screw Jack Gearbox**  
**Translation from German original**

Page	45	56
Name	Gansemer	2014-04-14
Released		

## 9. Maintenance



**Maintenance work may only be carried out by qualified or specially trained personnel!**

**Monitoring and protective equipment must not be put out of operation.**



**Before starting any maintenance work on screw-jack gearboxes the following points must be ensured:**



- The machine/system, in which the gearbox is installed, must be at a standstill.
- The machine/system must be secured against inadvertent starting.
- The machine/system must be sufficiently cooled off so that there is no danger of burns.
- The motor must be cut off from the mains.



The operator must ensure that, also after carrying out maintenance work, there is no risk of sparking. Any rotating or straight moving parts and any such parts which may get into contact with them should be protected against corrosion after completing the maintenance work (e.g. by greasing, painting, zinc coating).

## Maintenance intervals

Interval	What should be done?
Every 2000 machine hours, - at least every six months	<ul style="list-style-type: none"> <li>• Listen to running noises of the basic gear to detect possible damage to bearings.</li> <li>• Visual inspection for leakage at the motor flange and the seals. If there is a leakage, please contact us. Unnoticed loss of lubricant leads to wear, increased temperatures and sparking when running dry.</li> </ul>
Continuously, at least weekly	<ul style="list-style-type: none"> <li>• Re-lubricate the trapezoidal-thread nut (see 7.1). We recommend to use our lubricator.</li> </ul>
At least once a year	<ul style="list-style-type: none"> <li>• Clean spindle from old grease (see 9.1)</li> </ul>
Depending upon operating conditions	<ul style="list-style-type: none"> <li>• Clean basic gear ( see 9.2)</li> </ul>
After 1000 m travelling distance, at least every 6 months	<ul style="list-style-type: none"> <li>• Measure the wear at the trapezoidal-thread nut (see 9.4)</li> </ul>
At least once a year	<ul style="list-style-type: none"> <li>• Measure the wear of the motor brake (see 9.6)</li> </ul>



# ATLANTA

## BWL 350

### Operating and Maintenance Instructions

### 4100-001-12.93

Dept.		<b>TS - Screw Jack Gearbox</b> <b>Translation from German original</b>	Page	46	56
Rev.Index			Name	Gansemer	2014-04-14
Date			Released		

#### 9.1. Cleaning the spindle from grease/replacing the lubricator:



The spindle must be thoroughly cleaned from old grease once a year or at the end of the emptying time of the lubricator and then it has to be greased again over the full useful length. Depending on the working conditions (dust, moisture, etc.) it must be completely cleaned at shorter intervals in order to ensure adequate lubrication of spindle and nut. Insufficient lubrication will cause increased wear.



The filling in the lubricator must be checked regularly. We recommend to include this work in a maintenance plan. When the lubricator is completely empty, it can be refilled for further use. Only the pressure chamber, where the gas generation takes place and which is supplied by us as a spare part, has to be replaced. A permanent signal lamp, powered by two standard 1.5 V batteries, signals that the lubricator is ready for operation. Our instructions BKI 103 are available on our homepage. When refilling the lubricator care should be taken that no air bubbles develop inside the lubricator due to the consistency of the grease. They cause an interruption of the lubricant supply when they are carried through the hose to the lubricating point.

#### 9.2. Cleaning the basic gear unit:



Dust on the gearbox in excess of 5mm thickness is not acceptable because, due to the dust layer, the surface temperature is excessively increased so that the dust may ignite. Keep the surface clean.



Cleaning with high-pressure cleaners is not permissible. It leads to the destruction of the seals and penetration of water into the gearbox and consequently to premature failure of the gear unit.



Do not clean the gear unit, and in particular the area of the seals, with sharp-edged objects. Cleaning with solvents or cleaning agents is only permissible if these are released in writing by ATLANTA E.Seidenspinner GmbH & Co. KG.



After cleaning the basic gear unit it is necessary to grease the spindle and the nut again. Attachments of steel are to be protected again against corrosion, if necessary.



# ATLANTA

## BWL 350

### Operating and Maintenance Instructions

### 4100-001-12.93

Dept.	
Rev.Index	
Date	

**TS - Screw Jack Gearbox**  
**Translation from German original**

Page	47	56
Name	Gansemer	2014-04-14
Released		

### 9.3. Changing the gearbox lubricant:



**Before changing the lubricant the gearbox must be cooled off until it is not more than lukewarm.**



Lubricants (oils and fats) are hazardous substances that may pollute soil and water. Collect the drained lubricant in suitable containers and dispose of it in accordance with the applicable national regulations.

Prevent the lubricant from penetrating into drains, sewerage and rivers or lakes.



Under the following conditions grease lubrication is a lifetime lubrication:

- The design of the gear unit is strictly in accordance with the guidelines specified in the ATLANTA catalogue.
- The gear unit is operated exclusively between the allowable characteristic values and limit values.
- The user checks the gear unit regularly for loss of lubricant.
- The surface temperature attains max. 80° C.



If operated under different working conditions, we recommend to remove the old grease and clean the gear unit after approx. 600 operating hours or 2 years and to fill it with new grease. ATLANTA recommendation: Blasolube 306 from Fa. Blaser  
The gear unit is supplied filled with this type of grease.

### 9.4. Measuring the wear of the trapezoidal-thread nut:



**The trapezoidal-thread nut is a safety relevant component. It transmits the axial forces**



The motion in trapezoidal-thread drives is sliding. Depending on load and lubrication this will lead to wear on the trapezoidal-thread nut. As soon as the wear exceeds a certain tolerable degree, the bearing nut must be replaced to prevent a breakdown of the whole system.



Increased noise, unwieldy transmission and consequently increased power drain are an indication for wear. We recommend to measure the power drain and to compare the value with the reference value measured after start-up. (See para 6.)



**Before removing the fork link, spherical plain bearing rod head, swivel head, spindle-fixing flange or spindle nut, the system must be supported by suitable measures so that the spindle/nut is not under load.**



# ATLANTA

## BWL 350

### Operating and Maintenance Instructions

### 4100-001-12.93

Dept.	
Rev.Index	
Date	

**TS - Screw Jack Gearbox**  
**Translation from German original**

Page	48	56
Name	Gansemer	2014-04-14
Released		

**Gear unit with non-rotating spindle:**

In units with non-rotating spindles the wear can only be measured indirectly.

- The wear is about equal to the axial play of the trapezoidal-thread nut.
- For determining the axial play, support the attachment to which the spindle end is fixed (with fork link, spherical plain bearing rod head, swivel head, or fixing flange). Then remove the fork link, spherical plain bearing rod head, swivel head, or the fixing flange from the attachment and rotate the spindle downwards by 2-3 rotations.
- Move the spindle in the direction of the attachment so that flanks are in touch and then measure the distance between bore of fork link/ spherical plain bearing rod head / swivel head, or contact surface of fixing flange and attachment.
- Move the spindle in the direction opposite the attachment so that flanks are in touch and repeat the measurement.
- The difference between the distances measured corresponds directly to the wear. The maximum permissible wear (V max.) can be seen in the table below.
- If the maximum permissible wear is exceeded, the bearing nut must be replaced.

**Gear units with rotating spindle without safety grip nut:**

Here, too, the wear can be determined only indirectly:

- The wear corresponds approximately to the axial play of the trapezoidal-thread nut.
- For determining the axial play, support the attachment, to which the nut is fixed.
- Then screw off the nut from the attachment and rotate downwards by 2-3 turns.
- Move the nut in direction to the attachment until the flanks are in touch and then measure the distance between nut and attachment.
- Move the nut in the direction opposite the attachment until flanks are in touch and then repeat the measurement.
- The difference between the distances measured corresponds directly to the wear. The maximum permissible wear (V max.) can be seen in the table below.
- If the maximum permissible wear is exceeded, the bearing nut must be replaced.





# ATLANTA

## BWL 350

### Operating and Maintenance Instructions

### 4100-001-12.93

Dept.	
Rev.Index	
Date	

**TS - Screw Jack Gearbox**  
**Translation from German original**

Page	49	56
Name	Gansemer	2014-04-14
Released		



#### Gear unit with rotating spindle and safety grip nut:

Here the wear can be measured directly.

- Measure the distance between the bearing nut and the grip nut.
- This is the dimension „Y“ of the following calculation formula.
- The distance between bearing nut and safety grip nut, i.e. the dimension „X“ at the time supplied is noted on the enclosed nameplate (see para 5.4.).



- The permissible wear can be calculated from the difference of the two distances:  
**V max = X – Y**
- It can be read from the table below.
- When the max. allowable wear is exceeded, the bearing nut must be replaced.

Dimension of spindle	Max. permissible wear <b>V max</b> [mm]
Tr 14x4, Tr 18x4, Tr 20x4	1.2
Tr 30x6	1.8
Tr 40x7	2.0
Tr 60x9	2.5

Example: Spindle Tr18x4

Dimension on nameplate: X = 2.45 mm (this is the distance existing at the time of delivery)

Measured distance: Y = 1.25 mm

Vorhandener Verschleiß: V = X – Y = 2.45 – 1.25 = 1.2 mm = V max

Result: The bearing nut must be replaced.

#### 9.5. Replacing the trapezoidal-thread nut:



**The trapezoidal-thread nut is a safety-relevant component. It transmits the axial loads.**



If the wear exceeds the degree „V max“ mentioned in para. 9.4 , the trapezoidal-thread nut has to be replaced. Otherwise there is a risk that the threads break and the machine/system collapses.



**Before replacing the trapezoidal-thread nut, it must be ensured that the load cannot start moving. The best thing is to dismount the gear unit for the replacement of the nut.**



#### Gear unit with non-rotating spindle:

The trapezoidal-thread nut is integrated in the worm wheel and is within the gear unit. Therefore the gear unit must be sent to ATLANTA for replacing the trapezoidal-thread nut and, if necessary, the spindle.



# ATLANTA

## Operating and Maintenance Instructions

### BWL 350

### 4100-001-12.93

Dept.	
Rev.Index	
Date	

**TS - Screw Jack Gearbox**  
**Translation from German original**

Page	50	56
Name	Gansemer	2014-04-14
Released		



**Gear unit with rotating spindle:**

In the case of gear units with rotating spindle, it is possible to replace the nut. For this purpose support the load and dismount existing attachments. Dismount the spindle nut. Install new spindle nut. Observe the respective information in para. 5 and para. 7.

When replacing the trapezoidal-thread nut, inspect also the spindle for traces of wear (grooves, recesses, reduction of threads) and replace it as well, if necessary. A new spindle must be greased on its useful range before starting operation.

**9.6. Measuring the wear of the motor brake:**



**Before releasing the motor brake make sure that the load cannot start moving.**



The brake linings of the motor brake are subject to wear. They must be inspected at least once a year and the air gap should be adjusted, if necessary.

**Carefully read and observe the operating and maintenance instructions for the motor and the brake.**

When the wear limit mentioned in these instructions is reached, the brake linings must be replaced.

In the case of high switching frequencies, this inspection should be made more frequently, we recommend quarterly.



# ATLANTA

## Operating and Maintenance Instructions

# BWL 350

## 4100-001-12.93

Dept.	
Rev.Index	
Date	

**TS - Screw Jack Gearbox**  
**Translation from German original**

Page	51	56
Name	Gansemer	2014-04-14
Released		

### 9.7. Replacing the spindle:



The spindle is a safety-relevant component. It transmits the axial forces.



**Before starting to replace the spindle, it must be assured that the load is securely supported and cannot start moving. It is recommended to dismantle the gearbox before replacing the spindle.**



#### **Gear unit with non-rotating spindle:**

- Dismount the spindle fixing flange, fork link, spherical plain bearing rod head, or swivel head.
- Dismount the protective tube. For this purpose loosen the 2 or 4 screws at the protective tube and remove the square tube.
- Screw out the spindle in the direction of the protective tube.
- With twisting protection:  
Insert new twisting protection and lock with strain pin.
- Screw new spindle from the side of the protective tube into the gearbox. Rotate by hand over the full length and check for easy running.
- Grease the spindle on the useful range.
- Now fix the spindle fixing flange / fork link / spherical plain bearing rod head / swivel head again observing the pertinent points under para 5.
- Re-install the protective tube, centering the position between tube and gearbox flange. Tighten the screws with the tightening torque listed in the table below.
- Re-install the gear unit into the system as described under para. 7.
- Check the switching position of the limit switches.

Gear unit	Screw size	Strength class of screws	Tightening <sup>*)</sup> torque
TS 2	M 5	8.8	5.9 Nm
TS 5	M 5	8.8	5.9 Nm
TS 10	M 5	8.8	5.9 Nm
TS 25	M 5	8.8	5.9 Nm
TS 50	M 6	8.8	10 Nm
TS 100	M 6	8.8	10 Nm

<sup>\*)</sup> Only use calibrated torque wrenches! If the tightening torque is too low, the required torque will not be transmitted. If the tightening torque is too high, the nuts will be overstrained and become unusable. Secure screws against loosening (e.g. with Loctite 243).



# ATLANTA

Operating and Maintenance Instructions

## BWL 350

### 4100-001-12.93

Dept.	
Rev.Index	
Date	

**TS - Screw Jack Gearbox**  
**Translation from German original**

Page	52	56
Name	Gansemer	2014-04-14
Released		



**Gear units with rotating spindle:**

- The spindle must be exchanged in our workshop.



# ATLANTA

## Operating and Maintenance Instructions

### BWL 350

### 4100-001-12.93

Dept.		<b>TS - Screw Jack Gearbox</b> <b>Translation from German original</b>	Page	53	56
Rev.Index			Name	Gansemer	2014-04-14
Date			Released		

## 10. Storing



If the gear unit is not installed immediately after delivery, the following precautions have to be taken:

- The ideal way of storing is in vertically suspended position with the spindle hanging freely.
- Alternatively: Store the gear unit with horizontal spindle and input shaft (worm-shaft) lying horizontally on top. Support the nut in such a way that the spindle comes to lie horizontally. In the case of long spindles the spindle must be supported additionally. Care should be taken that there is no other contact to any other objects.
- The spindle is greased. It must be carefully protected from dust. Before being mounted, the spindle must be cleaned from old grease and then greased again.
- Protect the gear unit against environmental influences (ozone, UV radiation, electric welding, dust, dirt, moisture, temperature fluctuations, shocks, etc.).
- Attachments e.g. motor or coupling are to be stored separately.
- Protect all steel components against corrosion.
- Occasional rotating the input shaft of the gear unit will facilitate the start-up after storage.



The max. storing time under these conditions is 2 years.



Before installing the gear unit after storage, all parts have to be inspected for possible rust stains. If there are any, they have to be removed. Then protect the parts once more against rust, e.g. by greasing, painting, zinc coating.

## 11. Disposal



Observe the applicable national regulations!

Dispose of the various parts separately in accordance with their nature and composition and the applicable country-specific regulations!

For example (this list is not exhaustive):

- Steel scrap:
  - Spindles
  - Gearbox swivel bearing
  - Bellows adaptor
  - Fork link, link rod head, pivot bearing head, fixing flange
  - Mating bearing flange
  - Protective tube
- Aluminum scrap:
  - Gear housing
  - Motor flanges
  - Couplings
- Bronze scrap:
  - Trapezoidal-thread nut
  - Worm wheel
  - Twisting protection
- Grease should be disposed of in accordance with the applicable regulations



# ATLANTA

Operating and Maintenance Instructions

## BWL 350

### 4100-001-12.93

Dept.	
Rev.Index	
Date	

**TS - Screw Jack Gearbox**  
Translation from German original

Page	54	56
Name	Gansemer	2014-04-14
Released		

**12.1. Motor connection diagram for three-phase motor without brake and limit switch at the protective tube for gear units with non-rotating spindle:**

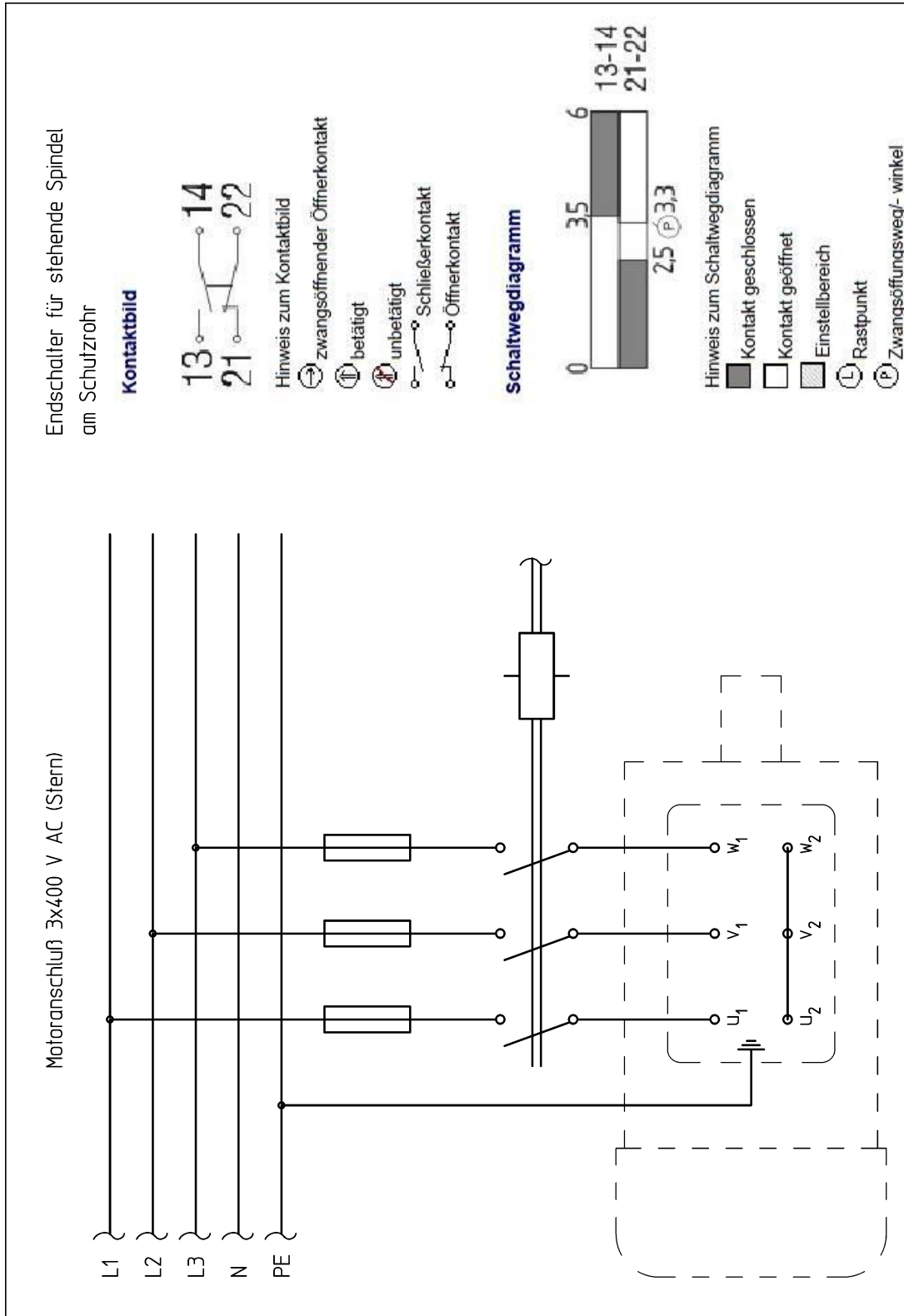



# ATLANTA

## Operating and Maintenance Instructions

### BWL 350

### 4100-001-12.93

Dept.	
Rev.Index	
Date	

**TS - Screw Jack Gearbox**  
**Translation from German original**

Page	55	56
Name	Gansemer	2014-04-14
Released		

Endschalter für stehende Spindel  
am Schutzrohr:

#### Kontaktbild

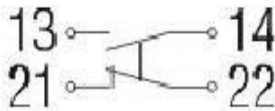

Hinweis zum Kontaktbild

- zwangsöffnender Öffnerkontakt
- betätigt
- unbetätigt
- Schließerkontakt
- Öffnerkontakt

#### Schaltwegdiagramm

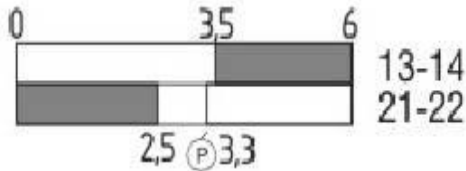

Hinweis zum Schaltwegdiagramm

- Kontakt geschlossen
- Kontakt geöffnet
- Einstellbereich
- Rastpunkt
- Zwangsöffnungsweg/-winkel

Limit switches for non-rotating spindle  
at the protective tube:

#### Diagram

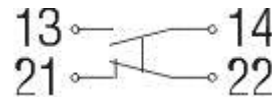

Notes to diagram

- positive break NC contact
- active
- no active
- Normally-open contact
- Normally-closed contact

#### Switch travel diagram

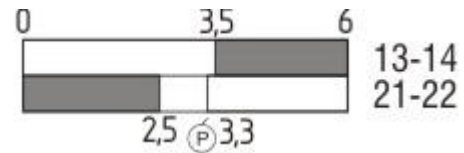

Notes to switch travel diagram

- Contact closed
- Contact open
- Setting range
- Break point
- Positive opening

Motoranschluss = motor connection

Bremsenanschluss = brake connection



# ATLANTA

## Operating and Maintenance Instructions

### BWL 350

### 4100-001-12.93

Dept.	
Rev.Index	
Date	

**TS - Screw Jack Gearbox**  
Translation from German original

Page	56	56
Name	Gansemer	2014-04-14
Released		

### 12.2. Motor connection diagram for three-phase motor with brake for gear units with rotating spindle:

