

Input speed ( $n_1$ ) = 1400 min<sup>-1</sup>

Output speed $n_2$ [min <sup>-1</sup> ]	Ratio $i$	Motor power $P_{1M}$ [kW]	Output torque $M_{2M}$ [Nm]	Service factor $f.s$	Nominal power $P_{1R}$ [kW]	Nominal torque $M_{2R}$ [Nm]	B5 motor flanges				B14 motor flanges				Dynamic efficiency RD	Tooth module [mm]	Ratio code
							-B 63	-C 71	-D 80	-O 56	-P 63	-Q 71	-R 80				
200	7	0.75	29	1.9	1.5	57	B	B			B-C	B		82	2.5	01	
140	10	0.75	41	1.5	1.1	62	B	B			B-C	B		80	2.4	02	
100	14	0.75	57	1.2	0.90	68	B	B			B-C	B		79	2.6	03	
78	18	0.55	51	1.2	0.67	62	B	B			B-C	B		75	2.0	04	
54	26	0.55	67	1.0	0.54	66	B	B			B-C	B		69	2.7	05	
47	30	0.55	79	0.9	0.50	72	B	B			B-C	B		70	2.5	12	
39	36	0.37	63	1.2	0.43	72	B				B-C	B-C		69	2.1	06	
33	43	0.37	72	1.0	0.35	68	B				B-C	B-C		66	1.8	07	
28	50	0.25	53	1.2	0.31	66	B				B-C	B-C		62	1.5	13	
23	60	0.25	59	1.0	0.26	62	B				B-C	B-C		58	1.3	08	
21	68	0.25	66	0.9	0.22	58	B				B-C	B-C		57	1.2	09	
17.5	80	0.18	53	1.1	0.19	57	B				B-C	B-C		54	1.0	10	
14	100	0.12	41	1.3	0.15	51	B				B-C	B-C		50	0.8	11	

**Motor flanges available**  
Flange motore disponibili



**B) Supplied with reduction bushing**  
Fornito con bussola di riduzione



**B) Available on request without reduction bushing**  
Disponibile a richiesta senza bussola di riduzione



**C) Motor flange holes position**  
Posizione fori flangia motore

## Lubrication

### Lubrificazione

Unit D50 is supplied with synthetic oil to assure long life lubrication. Food grade oil is available on request. See Table 1 for lubrication and recommended quantity. See Table 2 for possible radial and axial loads on the gearbox.

Il riduttore tipo D50 viene fornito con olio sintetico e lubrificazione tipo "long life". Disponibile a richiesta olio alimentare. Vedi Tabella 1 per oli e quantità consigliati. Vedi Tabella 2 per i carichi radiali e assiali applicabili al riduttore.

Oil quantity for all positions: 0.14 L	Shell Omala S4 WE 320	Eni Telium VSF 320
Quantità olio per tutte le posizioni: 0.14 L		

Tab. 1

## Suggested

### Suggerito

Stainless steel protection cap (on request).

Coperchio di protezione in acciaio inox a richiesta.

Kit cod. KN500209

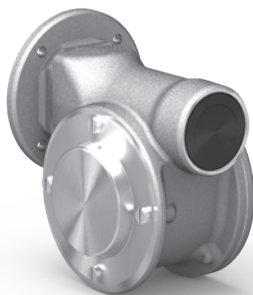

## Radial and axial loads

### Carichi radiali e assiali

#### Output shaft

Albero di uscita

$n_2$ [min <sup>-1</sup> ]	FA [N]	FR [N]
200	240	1200
150	280	1400
100	300	1500
75	340	1700
50	380	1900
25	480	2500
15	560	2800

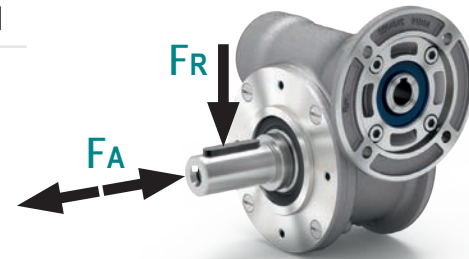

#### Input shaft

Albero in entrata

$n_1$ [min <sup>-1</sup> ]	FA [N]	FR [N]
1400	76	380

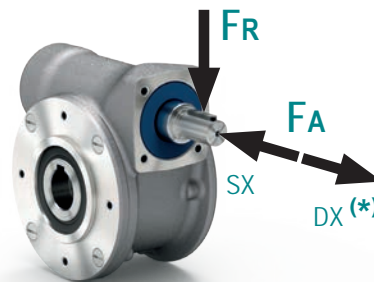

\* Strong axial loads in the DX direction are not allowed.  
\* Non sono consentiti forti carichi assiali con direzione DX

Tab. 2

PD50 **UNI..** Basic gearbox  
Riduttore base

M. flanges	Kit code	øF	A
63B5	KD504041	138	78.5
71B5	KD504042	160	76
80B5	KD504043	200	76.5
56B14	KD504049	80	76
63B14	KD504047	90	78.5
71B14	KD504045	105	76
80B14	KD504046	120	76.5

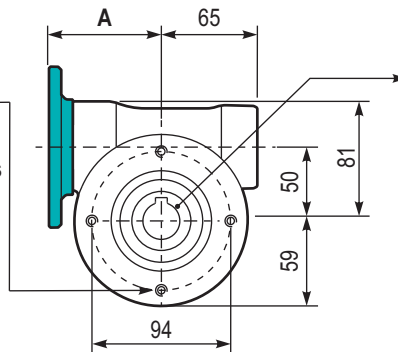
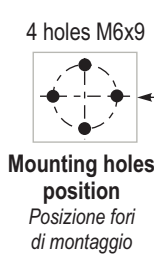
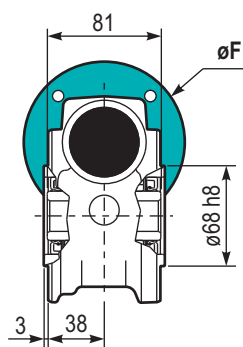

Gearbox weight  
Peso riduttore **3.00 kg**

Hollow shaft  
Foro in uscita

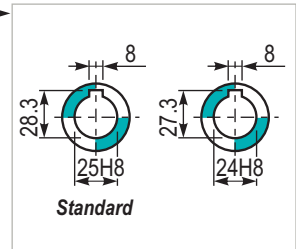

PD50 **PA...** Feet  
Piedini

Type	T	Kit code
B**	123	K0509022
I*	122	KN509022

\*\* Zink plated  
\* Stainless steel

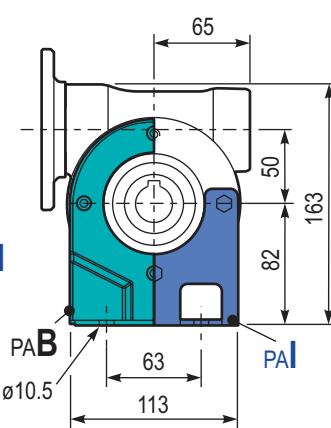
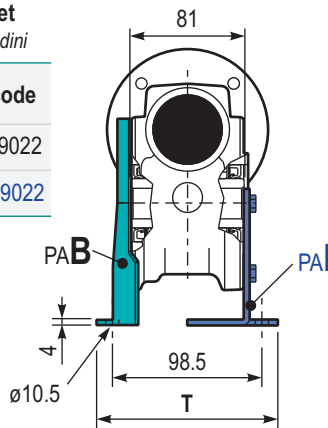

PD50 **PBB..** Feet  
Piedini

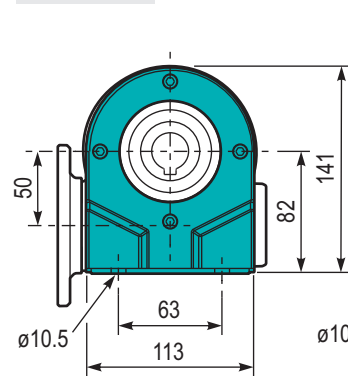

PD50 **PV...** Feet  
Piedini

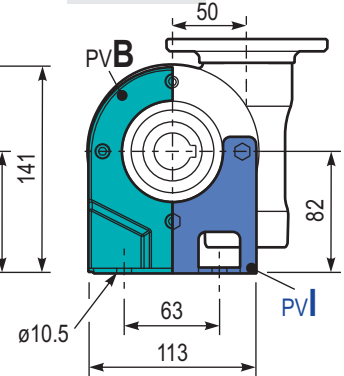

PD50 **FL..** Output flange  
Flangia uscita

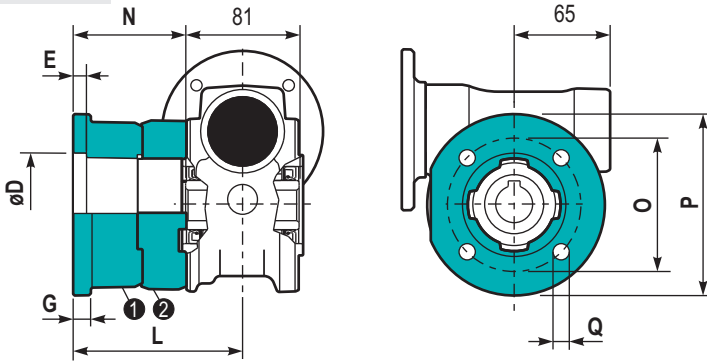

Type	øD	E	G	L	N	O	P	Q	Kit code
C	70 <sup>+0.20</sup> / <sub>+0.15</sub>	9	12	85	44.5	90	123	10.5	① K0509010 ② -
L	70 <sup>+0.20</sup> / <sub>+0.15</sub>	9	12	114.5	74	90	123	10.5	① K0509010 ② K0500200

PD50 **BR...** Reaction arm  
Braccio di reazione

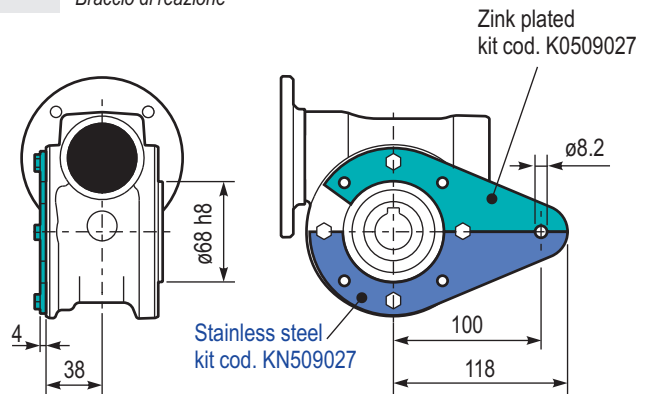

**RD50UNI..** Input shaft  
Albero in entrata

Carbon steel kit cod. K0505006 PAM71  
Carbon steel kit cod. K0505007 PAM80

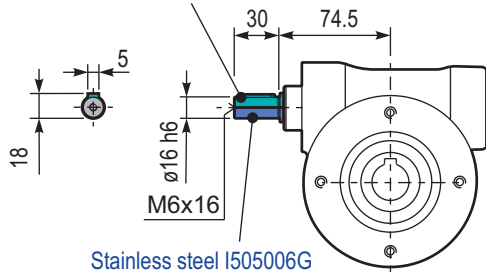

PD50 **SMF** Single output shaft  
Albero semplice in uscita

kit cod. KN500209  
**Protection cap (on request)**  
A richiesta coperchio di protezione

