

150

72 Nm

VFI series Full stainless steel square worm gearboxes

Riduttori a vite senza fine quadrati completamente in acciaio inox

Input speed (n_1) = 1400 min⁻¹

Output speed n_2 [min ⁻¹]	Ratio i	Motor power P_{1M} [kW]	Output torque M_{2M} [Nm]	Service factor $f.s$	Nominal power P_{1R} [kW]	Nominal torque M_{2R} [Nm]	B5 motor flanges			B14 motor flanges			Dynamic efficiency RD	Tooth module [mm]	Ratios code
							-	-	-	-P	-Q	-R			
							-	-	-	-P	-Q	-R			
							-	-	-	63	71	80	RD		
200	7	0.75	29	1.9	1.5	57				B-C	B		82	2.5	01
140	10	0.75	41	1.5	1.1	62				B-C	B		80	2.4	02
100	14	0.75	57	1.2	0.90	68				B-C	B		79	2.6	03
78	18	0.55	51	1.2	0.67	62				B-C	B		75	2.0	04
54	26	0.55	67	1.0	0.54	66				B-C	B		69	2.7	05
47	30	0.55	79	0.9	0.50	72				B-C	B		70	2.5	12
39	36	0.37	63	1.2	0.43	72				B-C			69	2.1	06
33	43	0.37	72	1.0	0.35	68				B-C			66	1.8	07
28	50	0.25	53	1.2	0.31	66				B-C			62	1.5	13
23	60	0.25	59	1.0	0.26	62				B-C			58	1.3	08
21	68	0.25	66	0.9	0.22	58				B-C			57	1.2	09
17.5	80	0.18	53	1.1	0.19	57				B-C			54	1.0	10
14	100	0.12	41	1.3	0.15	51				B-C			50	0.8	11

Motor flanges available
Flange motore disponibili



B) Supplied with reduction bushing
Fornito con bussola di riduzione



B) Available on request without reduction bushing
Disponibile a richiesta senza bussola di riduzione



C) Motor flange holes position
Posizione fori flangia motore

Lubrication

Lubrificazione

Unit 150 is supplied with synthetic oil to assure long life lubrication. Food grade oil is available on request. See Table 1 for lubrication and recommended quantity. See Table 2 for possible radial and axial loads on the gearbox.

Il riduttore tipo 150 viene fornito con olio sintetico e lubrificazione tipo "long life". Disponibile a richiesta olio alimentare. Vedi Tabella 1 per oli e quantità consigliati. Vedi Tabella 2 per i carichi radiali e assiali applicabili al riduttore.

Shell Omala S4 WE 320

Eni Telium VSF 320

B3
Standard
0.22 L

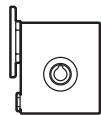

B8
On request
0.22 L

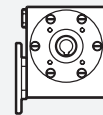

B6
On request
0.22 L

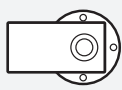

V5
On request
0.22 L

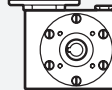

B7
On request
0.28 L

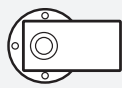

V6
On request
0.22 L

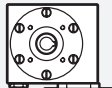

For more details on lubrication and plugs check our website.
Per maggiori dettagli su lubrificazione e tappi olio vedi il nostro sito web.

Tab. 1

Suggested

Sugerito

Stainless steel protection cap (on request).
Coperchio di protezione in acciaio inox a richiesta.

Kit cod. KI500211



Radial and axial loads

Carichi radiali e assiali

Output shaft

Albero di uscita

n_2 [min ⁻¹]	FA [N]	FR [N]
200	240	1200
150	280	1400
100	300	1500
75	340	1700
50	380	1900
25	480	2500
15	560	2800

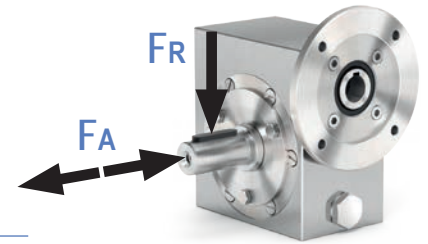

Input shaft

Albero in entrata

n_1 [min ⁻¹]	FA [N]	FR [N]
1400	76	380

* Strong axial loads in the DX direction are not allowed.

* Non sono consentiti forti carichi assiali con direzione DX

Tab. 2

PI50UNI... **Basic gearbox**
Riduttore base

Gearbox weight **7.3 kg**
peso riduttore

M. flanges	Kit code	øF	A
63B14	KI504047	90	78
71B14	KI504045	105	75.5
80B14	KI504046	120	76

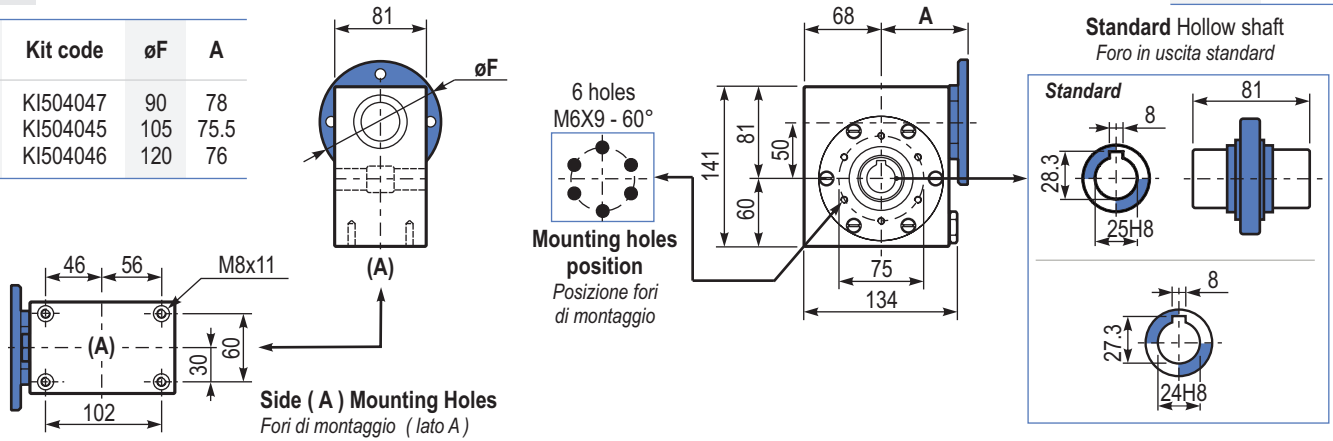

BI50UNI... **Modular base**
Base modulare

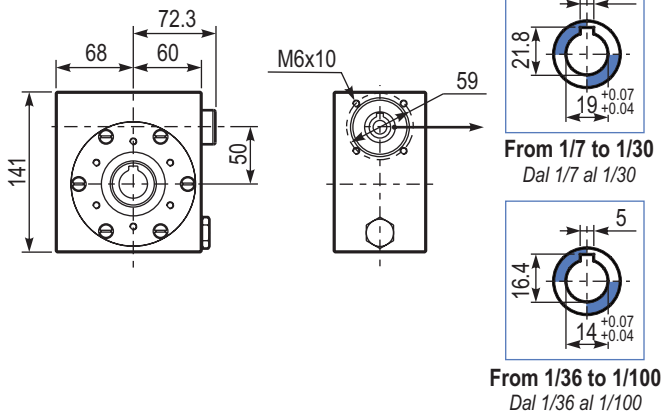

PI50FLL... **Output flange**
Flangia uscita

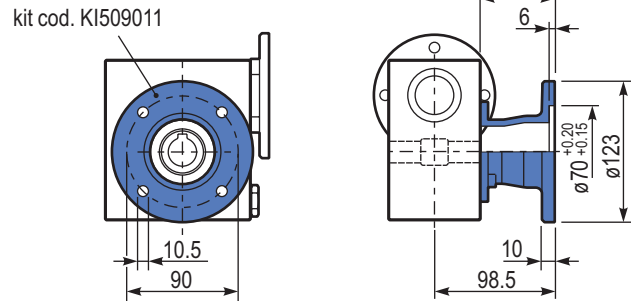

RI50UNI... **Input shaft**
Albero in entrata

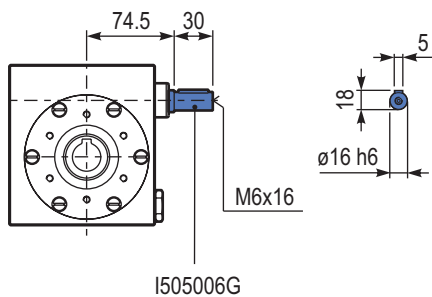

PI50BRI... **Reaction arm**
Braccio di reazione

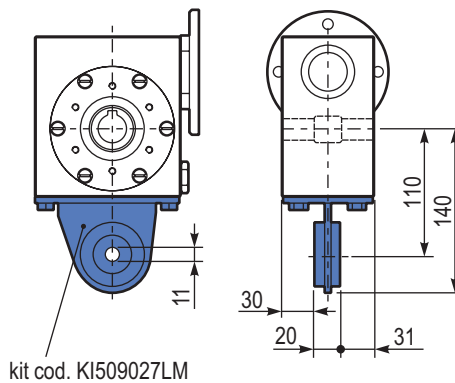

PI50...SMF.. **Single Shaft**
Albero lento semplice

