

Input speed (n_1) = 1400 min⁻¹

Output speed n_2 [min ⁻¹]	Ratio i	Motor power P_{1M} [kW]	Output torque M_{2M} [Nm]	Service factor $f.s$	Nominal power P_{1R} [kW]	Nominal torque M_{2R} [Nm]	B5 motor flanges		B14 motor flanges		Dynamic efficiency RD	Tooth module [mm]	Ratio code
							-	-	-P 63	-Q 71			
200	7	0.37	14	2.2	0.80	30			B-C		80	2.2	01
140	10	0.37	20	1.5	0.57	30			B-C		79	2.2	02
100	14	0.37	27	1.1	0.41	30			B-C		77	2.4	03
67	21	0.37	36	1.2	0.43	41			B-C		67	1.6	04
50	28	0.25	31	1.3	0.33	41			B-C		65	2.5	05
38	37	0.25	40	1.0	0.26	41			B-C		63	1.8	06
30	46	0.25	46	0.9	0.22	41			B-C		59	1.5	07
23	60	0.18	41	1.0	0.18	41			B-C		56	1.2	08
20	70	0.12	31	1.0	0.12	30			B-C		54	1.0	09
13.7	102	0.12	41	0.7	0.09	29			B-C		49	0.72	10

Motor flanges available
Flange motore disponibili

B) Supplied with reduction bushing
Fornito con bussola di riduzione

B) Available on request without reduction bushing
Disponibile a richiesta senza bussola di riduzione

C) Motor flange holes position
Posizione fori flangia motore

Lubrication

Lubrificazione

Unit N45 is supplied with synthetic oil to assure long life lubrication. Food grade oil is available on request.

See Table 1 for lubrication and recommended quantity.

See Table 2 for possible radial and axial loads on the gearbox.

Il riduttore tipo N45 viene fornito con olio sintetico e lubrificazione tipo "long life". Disponibile a richiesta olio alimentare.

Vedi Tabella 1 per oli e quantità consigliati.

Vedi Tabella 2 per i carichi radiali e assiali applicabili al riduttore.

Oil quantity for all positions:
0.13 L

Quantità olio per tutte le posizioni: 0.13 L

Shell
Omala S4 WE 320

Eni
Telium VSF 320

Tab. 1

Suggested

Suggerito

Stainless steel protection cap (on request).

Coperchio di protezione in acciaio inox a richiesta.

Kit cod. KN300209

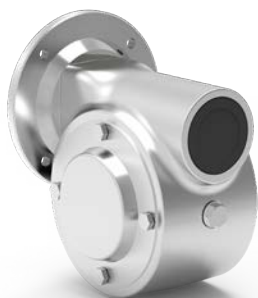

Radial and axial loads

Carichi radiali e assiali

Output shaft

Albero di uscita

n_2 [min ⁻¹]	F_A [N]	F_R [N]
200	180	900
150	200	1000
100	220	1100
75	240	1200
50	260	1400
25	300	1800
15	400	2000

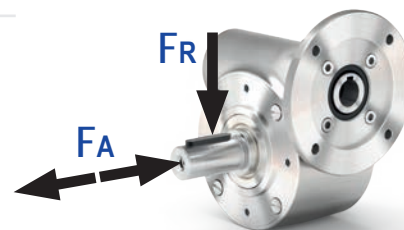

Input shaft

Albero in entrata

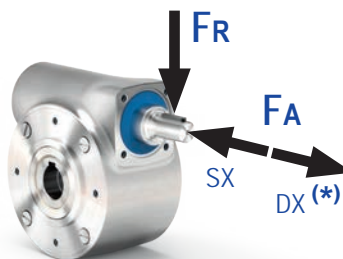

n_1 [min ⁻¹]	F_A [N]	F_R [N]
1400	42	210

* Strong axial loads in the DX direction are not allowed.

* Non sono consentiti forti carichi assiali con direzione DX

Tab. 2

PN45UNI.. Basic gearbox
Riduttore base

M. flanges	Kit code	øF	A
63B14	KI504047	90	73.5
71B14	KI504045	105	71

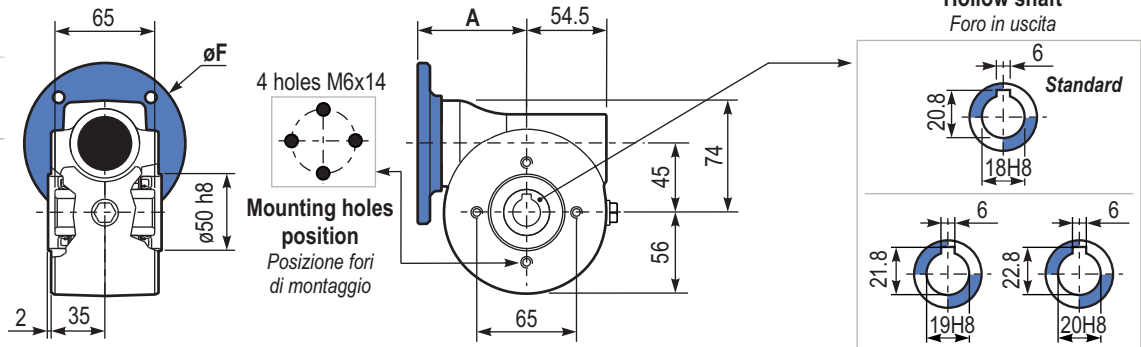

Gearbox weight
Peso riduttore **4.1 kg**

PN45PAI.. Feet
Piedini

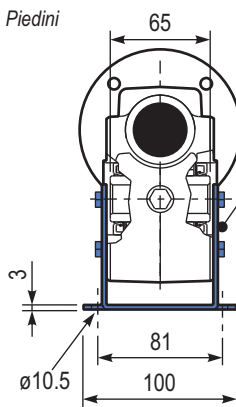

kit cod. KN459022

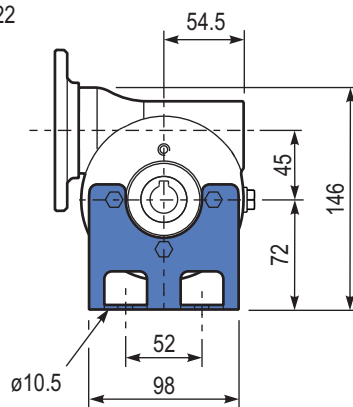

PN45PVI.. Feet
Piedini

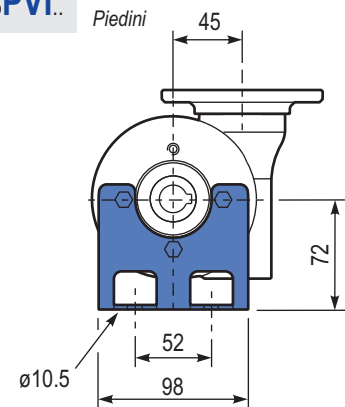

PN45FLL.. Output flange
Flangia uscita

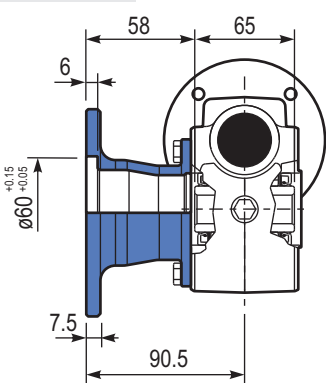

kit cod. KN459011

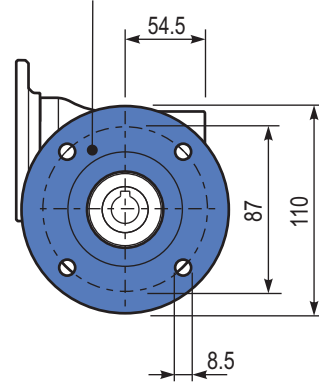

PN45BRI.. Reaction arm
Braccio di reazione

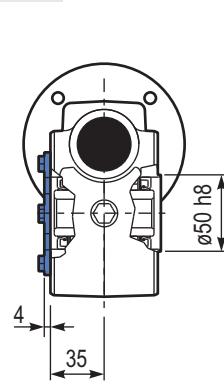

kit cod. KN459027

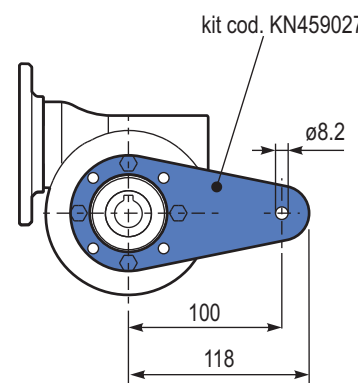

RN45UNI.. Input shaft
Albero in entrata

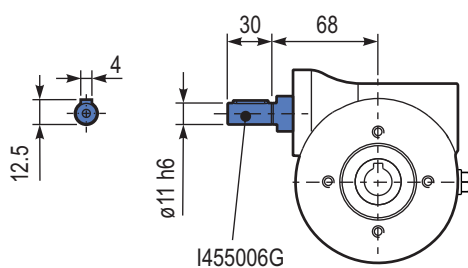

PN45..SMB Single output shaft
Albero semplice in uscita

