

Input speed (n_1) = 1400 min⁻¹

Output speed n_2 [min ⁻¹]	Ratio i	Motor power P_{1M} [kW]	Output torque M_{2M} [Nm]	Service factor $f.s$	Nominal power P_{1R} [kW]	Nominal torque M_{2R} [Nm]	B5 motor flanges			B14 motor flanges			Dynamic efficiency RD	Tooth module [mm]	Ratio code
							-	-	-	-P 63	-Q 71	-R 80			
200	7	0.75	29	1.9	1.5	57				B-C	B		82	2.5	01
140	10	0.75	41	1.5	1.1	62				B-C	B		80	2.4	02
100	14	0.75	57	1.2	0.90	68				B-C	B		79	2.6	03
78	18	0.55	51	1.2	0.67	62				B-C	B		75	2.0	04
54	26	0.55	67	1.0	0.54	66				B-C	B		69	2.7	05
47	30	0.55	79	0.9	0.50	72				B-C	B		70	2.5	12
39	36	0.37	63	1.2	0.43	72				B-C			69	2.1	06
33	43	0.37	72	1.0	0.35	68				B-C			66	1.8	07
28	50	0.25	53	1.2	0.31	66				B-C			62	1.5	13
23	60	0.25	59	1.0	0.26	62				B-C			58	1.3	08
21	68	0.25	66	0.9	0.22	58				B-C			57	1.2	09
17.5	80	0.18	53	1.1	0.19	57				B-C			54	1.0	10
14	100	0.12	41	1.3	0.15	51				B-C			50	0.8	11

Motor flanges available
Flange motore disponibili



B) Supplied with reduction bushing
Fornito con bussola di riduzione



B) Available on request without reduction bushing
Disponibile a richiesta senza bussola di riduzione



C) Motor flange holes position
Posizione fori flangia motore

Lubrication

Lubrificazione

Unit N50 is supplied with synthetic oil to assure long life lubrication. Food grade oil is available on request. See Table 1 for lubrication and recommended quantity. See Table 2 for possible radial and axial loads on the gearbox.

Il riduttore tipo N50 viene fornito con olio sintetico e lubrificazione tipo "long life". Disponibile a richiesta olio alimentare. Vedi Tabella 1 per oli e quantità consigliati. Vedi Tabella 2 per i carichi radiali e assiali applicabili al riduttore.

Oil quantity for all positions:
0.18 L

Quantità olio per tutte le posizioni: 0.18 L

Shell
Omala S4 WE 320

Eni
Teliuim VSF 320

Tab. 1

Suggested

Suggerito

Stainless steel protection cap (on request).

Coperchio di protezione in acciaio inox a richiesta.

Kit cod. KN500209

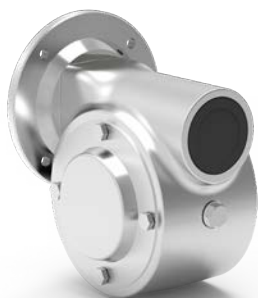

Radial and axial loads

Carichi radiali e assiali

Output shaft

Albero di uscita

n_2 [min ⁻¹]	FA [N]	FR [N]
200	240	1200
150	280	1400
100	300	1500
75	340	1700
50	380	1900
25	480	2500
15	560	2800

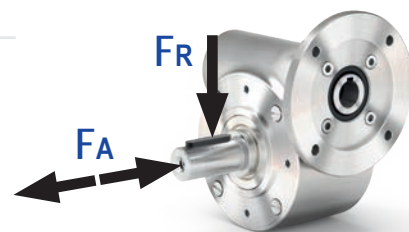

Input shaft

Albero in entrata

n_1 [min ⁻¹]	FA [N]	FR [N]
1400	76	380

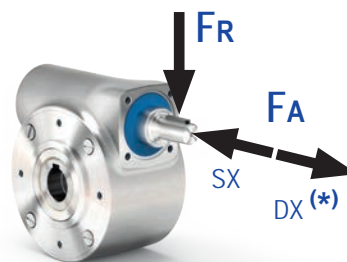

* Strong axial loads in the DX direction are not allowed.

* Non sono consentiti forti carichi assiali con direzione DX

Tab. 2

PN50UNI.. Basic gearbox
Riduttore base

M. flanges	Kit code	øF	A
63B14	KI504047	90	78
71B14	KI504045	105	75.5
80B14	KI504046	120	76

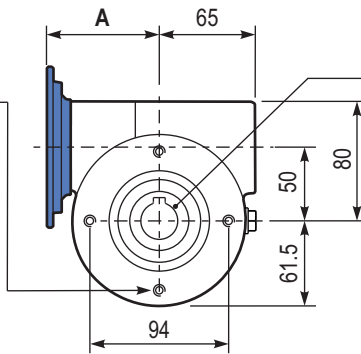
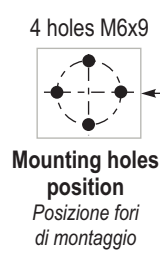
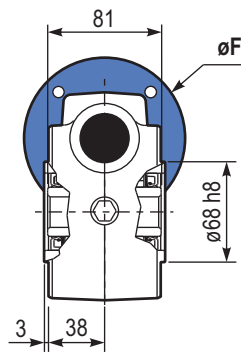

Gearbox weight
Peso riduttore **5.3 kg**

Hollow shaft
Foro in uscita

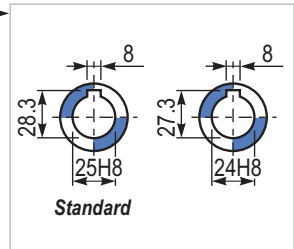

PN50PAI.. Feet
Piedini

kit cod. KN509022

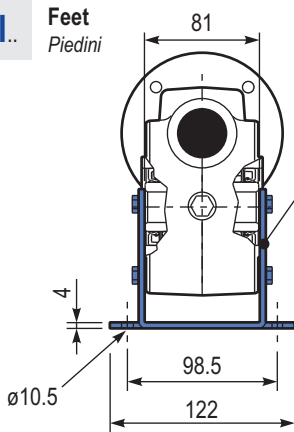

kit cod. KN509022

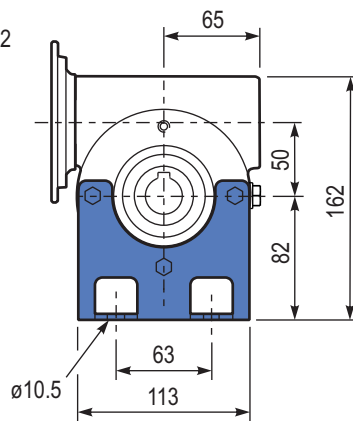

PN50PVI.. Feet
Piedini

kit cod. KN509027

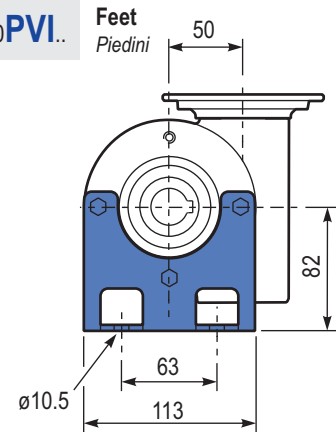

PN50FLL.. Output flange
Flangia uscita

kit cod. KN509011

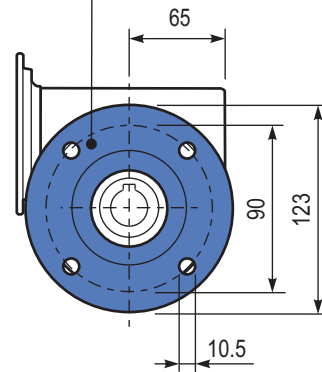
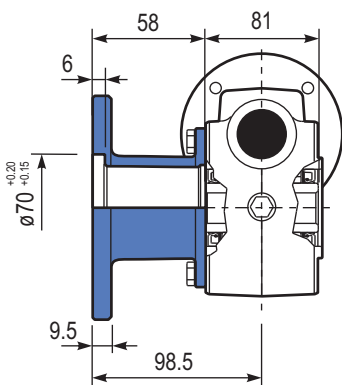

PN50BRI.. Reaction arm
Braccio di reazione

kit cod. KN509027

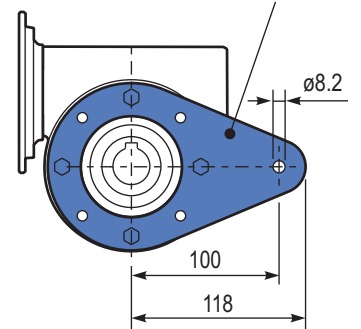
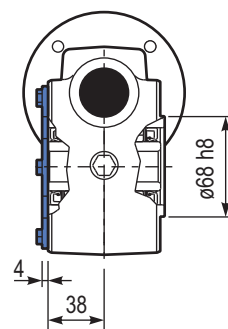

RN50UNI.. Input shaft
Albero in entrata

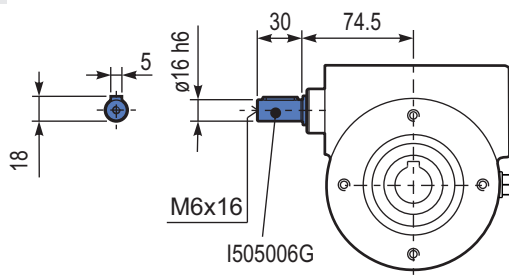

PN50..SMF Single output shaft
Albero semplice in uscita

kit cod. KN500209
Protection cap (on request)
A richiesta coperchio di protezione

