



N63 211N

VFN series with ratio multiplier RCN series

Riduttori a vite senza fine serie VFN in acciaio inox con precoppia serie RCN

N63 Ratios/Rating

Rapporti/Selezione N63

Ratio	Max output torque ** M_{2R} [Nm]	Tooth module  [mm]	Standard input bore	Ratio code 
i _a				
7	144	3.1	ø24	01
10	155	3.1	ø24	02
15	158	3.1	ø24	03
19	158	2.6	ø24	04
24	163	2.0	ø24	05
30	168	3.2	ø24	06
36	169	2.7	ø24	07
40	161	2.5	ø24	13
45	156	2.1	ø19	08
60	150	1.6	ø19	12
67	142	1.5	ø19	09
80	136	1.3	ø19	10
94	136	1.1	ø19	11

N63 weight
Peso N63

10.00 kg

211N Ratios/Power

Rapporti/potenza 211N

Ratio	Max input power ** P_{1M} [kW]	Standard output shaft	Ratios code 
i _b			
2.05	0.37	ø14	01
2.35	0.37	ø14	02
2.80	0.37	ø14	03
3.38	0.37	ø14	04
4.70	0.37	ø14	05
6.22	0.37	ø14	06
8.29	0.37	ø14	07
9.83	0.25	ø14	08

211N weight
Peso 211N

2.50 kg

211N Motor flanges

Flange motore 211N

	kit code	g6	A
63B14	KI504047	90	99.5
71B14	KI504045	105	97

How to connect N63+211N

Come collegare N63 + 211N

Worm gearbox	Ratio multiplier	Connection kit	
		With standard input bore	With coupling
Standard input bore	Output shaft		
N63	øN	211N	
Ratios from 1/7 ÷ 1/40	ø24	ø14	KBR14/24
Ratios from 1/45 ÷ 1/94	ø19		KD14P

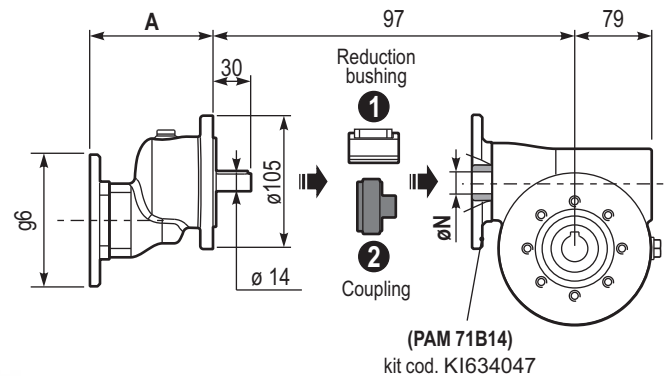

Ratios range: from 1/14 to 1/924

Range rapporti: da 1/14 a 1/924

Lubrication

Lubrificazione

Unit N63+211N is supplied with synthetic oil to assure long life lubrication. Food grade oil is available on request. See Table 1 for lubrication and recommended quantity.

Il riduttore tipo N63+211N viene fornito con olio sintetico e lubrificazione tipo "long life".

Disponibile a richiesta olio alimentare. Vedi Tabella 1 per oli e quantità consigliati.

For all details on lubrication and plugs check our website.

Per maggiori dettagli su lubrificazione e tappi olio vedi il nostro sito web.

N63: 0.45 L	SHELL: Omala S4 WE 320	ENI: Telium VSF 320
211N: 0.05 L	SHELL: Omala S4 WE 320	ENI: Telium VSF 320

Calculate total ratio and output speed

Calcola il rapporto totale e la velocità di uscita

Ratios range: from 1/14 to 1/924

Range rapporti: da 1/14 a 1/924

$$i_{TOT} = i_a \cdot i_b$$

Ex.: 1/94 x 1/9.83 = 1/924 (Max ratio)

Output speed (n₂)

Velocità di uscita

$$n_2 = n_1 : i_{TOT}$$

Ex.: 1448 : 924 = 1.57 rpm

i_a : N63 ratio - Rapporto N63

i_b : 211N ratio - Rapporto 211N

** Make sure input power for 211N and output torque for N63 is as catalogue ratios.

** Prestare attenzione a selezionare la potenza in entrata del 211N ed il momento torcente del N63 secondo le tabelle del catalogo.

n₁ Input speed

Velocità di ingresso

VFN series with ratio multiplier RCN series

N85 211N

Riduttori a vite senza fine serie VFN in acciaio inox con precoppia serie RCN

N85 Ratios/Rating

Rapporti/Selezione N85

Ratio	Max output torque $**M_{2R}$ [Nm]	Tooth module [mm]	Standard input bore	Ratio code
i_a				
7	296	4.23	ø28	01
10	326	4.2	ø28	02
14	350	4.5	ø28	03
20	338	3.4	ø28	04
22	338	3.1	ø28	05
28	398	4.7	ø28	06
38	386	3.5	ø24	07
46	374	3.1	ø24	08
52	332	2.7	ø24	09
67	332	2.1	ø24	10
74	308	1.9	ø24	11
96	278	1.5	ø24	12

N85 weight
Peso N85

21.00 kg

211N Ratios/Power

Rapporti/potenza 211N

Ratio	Max input power $**P_{1M}$ [kW]	Output shaft	Ratios code
i_b			
2.05	0.37	ø14	01
2.35	0.37	ø14	02
2.80	0.37	ø14	03
3.38	0.37	ø14	04
4.70	0.37	ø14	05
6.22	0.37	ø14	06
8.29	0.37	ø14	07
9.83	0.25	ø14	08

211N weight
Peso 211N

2.50 kg

211N Motor flanges

Flange motore 211N

	kit code	g6	A
63B14	KI504047	90	99.5
71B14	KI504045	105	97

How to connect N85+211N

Come collegare N85 + 211N

Worm gearbox	Ratio multiplier	Connection kit	
		With standard input bore	With coupling
Standard input bore	Output shaft		
N85	øN	211N	
Ratios from 1/7 ÷ 1/28	ø28	ø14	KBR14/28
Ratios from 1/38 ÷ 1/96	ø24		KBR14/24
			KE14P



Ratios range: from 1/14 to 1/944

Range rapporti: da 1/14 a 1/924

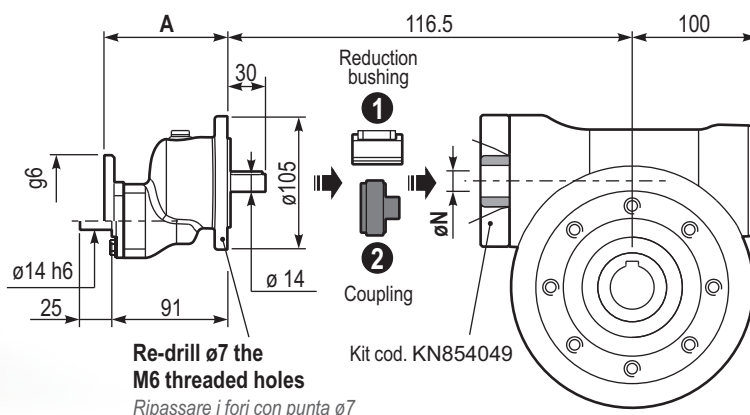

Lubrication

Lubrificazione

Unit N85+211N is supplied with synthetic oil to assure long life lubrication. Food grade oil is available on request. See Table 1 for lubrication and recommended quantity.

Il riduttore tipo N85+211N viene fornito con olio sintetico e lubrificazione tipo "long life".

Disponibile a richiesta olio alimentare. Vedi Tabella 1 per oli e quantità consigliati.

For all details on lubrication and plugs check our website.

Per maggiori dettagli su lubrificazione e tappi olio vedi il nostro sito web.

N85: 1.00 L	SHELL: Omala S4 WE 320	ENI: Telium VSF 320
211N: 0.05 L	SHELL: Omala S4 WE 320	ENI: Telium VSF 320

tab. 1

Calculate total ratio and output speed

Calcola il rapporto totale e la velocità di uscita

Ratios range: from 1/14 to 1/944

Range rapporti: da 1/14 a 1/924

$$i_{TOT} = i_a \cdot i_b$$

Ex.: $1/96 \times 1/9.83 = 1/944$ (Max ratio)

i_a : N85 ratio - Rapporto N85

i_b : 211N ratio - Rapporto 211N

** Make sure input power for 211N and output torque for N85 is as catalogue ratios.

** Prestare attenzione a selezionare la potenza in entrata del 211N ed il momento torcente del N85 secondo le tabelle del catalogo.

Output speed (n_2)

Velocità di uscita

$$n_2 = n_1 : i_{TOT}$$

Ex.: $1448 : 944 = 1.53$ rpm

n_1 Input speed

Velocità di ingresso