

Input speed (n_1) = 1400 min⁻¹

Output speed n_2 [min ⁻¹]	Ratio i	Motor power P_{1M} [kW]	Output torque M_{2M} [Nm]	Service factor $f.s$	Nominal power P_{1R} [kW]	Nominal torque M_{2R} [Nm]	B5 motor flanges				B14 motor flanges			Dynamic efficiency RD	Tooth module [mm]	Ratio code
							-	-	-	-	-R	-T	-U			
200	7	4.0	168	1.5	6.1	257	-	-	-	-	B	B		88	4.23	01
140	10	4.0	218	1.3	5.2	284	-	-	-	-	B	B		80	4.2	02
100	14	3.0	223	1.4	4.1	305	-	-	-	-	B	B		78	4.5	03
70	20	2.2	237	1.2	2.7	294	-	-	-	-	B	B		79	3.4	04
64	22	2.2	258	1.1	2.5	294	-	-	-	-	B	B		78	3.1	05
50	28	2.2	315	1.1	2.4	347	-	-	-	-	B	B		75	4.7	06
37	38	1.5	276	1.2	1.8	336	-	-	-	-	B	B		71	3.5	07
30	46	1.5	320	1.0	1.5	326	-	-	-	-	B	B		68	3.1	08
27	52	1.1	258	1.1	1.2	289	-	-	-	-	B	B		66	2.7	09
21	67	1.1	327	0.9	0.97	289	-	-	-	-	B	B		65	2.1	10
18.9	74	0.75	220	1.2	0.91	268	-	-	-	-	B	B		58	1.9	11
14.6	96	0.55	191	1.3	0.70	242	-	-	-	-	B	B		53	1.5	12

Motor flanges available
Flange motore disponibili



B) Supplied with reduction bushing
Fornito con bussola di riduzione



B) Available on request without reduction bushing
Disponibile a richiesta senza bussola di riduzione



C) Motor flange holes position
Posizione fori flangia motore

Lubrication

Lubrificazione

Unit N85 is supplied with synthetic oil to assure long life lubrication.
Food grade oil is available on request.
See Table 1 for lubrication and recommended quantity.
See Table 2 for possible radial and axial loads on the gearbox.

Il riduttore tipo N85 viene fornito con olio sintetico e lubrificazione tipo "long life".
Disponibile a richiesta olio alimentare.
Vedi Tabella 1 per oli e quantità consigliati.
Vedi Tabella 2 per i carichi radiali e assiali applicabili al riduttore.

Oil quantity for all positions:
1.0 L

Quantità olio per tutte le posizioni: 1.0 L

Shell
Omala S4 WE 320

Eni
Telium VSF 320

Tab. 1

Suggested

Suggerito

Stainless steel protection cap (on request).

Coperchio di protezione in acciaio inox a richiesta.

Kit cod. KN850209

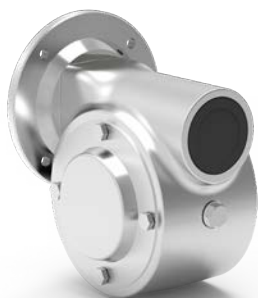

Radial and axial loads

Carichi radiali e assiali

Output shaft

Albero di uscita

n_2 [min ⁻¹]	FA [N]	FR [N]
200	500	2500
150	580	2900
100	600	3000
75	700	3500
50	800	4000
25	1000	5000
15	1160	5800

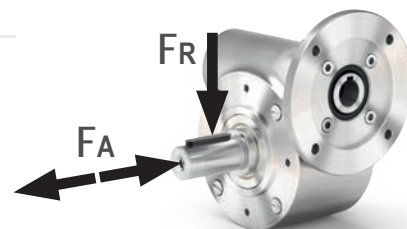

Input shaft

Albero in entrata

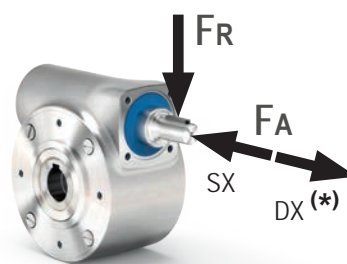

n_1 [min ⁻¹]	FA [N]	FR [N]
1400	130	650

* Strong axial loads in the DX direction are not allowed.

* Non sono consentiti forti carichi assiali con direzione DX

Tab. 2

PN85UNI.. Basic gearbox
Riduttore base

Gearbox weight
Peso riduttore 21.0 kg

M. flanges	Kit code	øF	A
80B14	KI854046	120	118
90B14	KI854045	140	118
100/112B14	KI854041	160	127

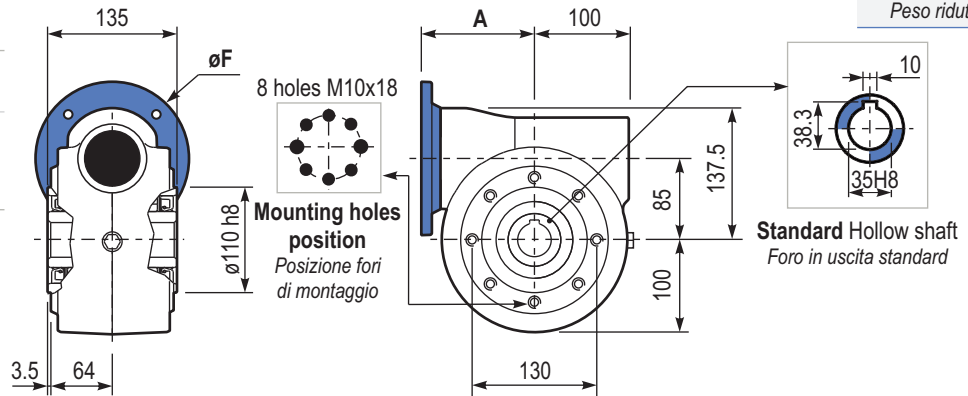

PN85PAI.. Feet
Piedini

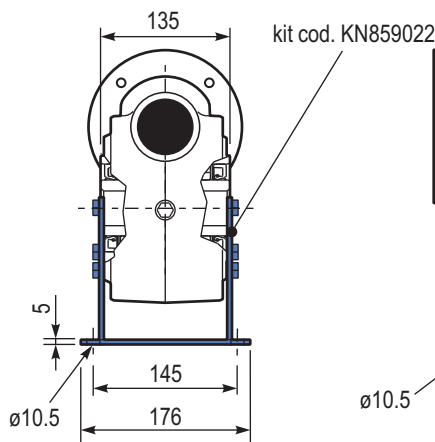

PN85PVI.. Feet
Piedini

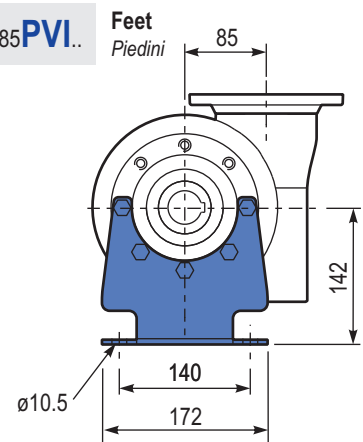

PN85FLL.. Output flange
Flangia uscita

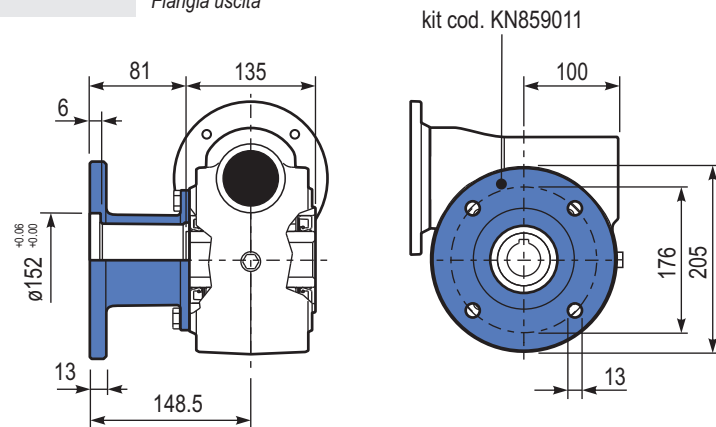

PN85BRI.. Reaction arm
Braccio di reazione

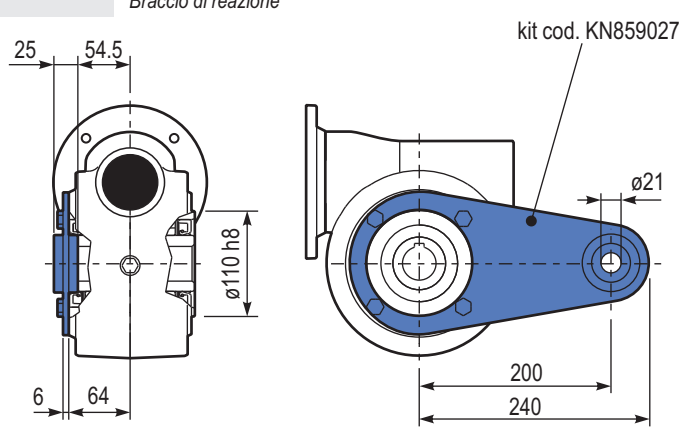

RN85UNI.. Input shaft
Albero in entrata

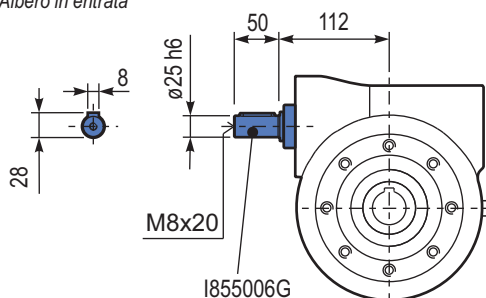

PN85..SMK Single output shaft
Albero semplice in uscita

